



**Manuale Installazione, Uso e Manutenzione
Argani Idraulici**

**Installation, operation and servicing manual for
Hydraulic Winches**

**Handbuch zur Installation, Verwendung und War-tung von
Hydraulikwinden**

INDEX

1 GENERAL INFORMATION	75
1.1 MANUFACTURER'S IDENTIFICATION DATA	75
1.2 WINCH IDENTIFICATION DATA	75
1.3 USING THIS INSTRUCTION MANUAL	76
1.4 EXCLUSION OF LIABILITY	76
1.5 INSTRUCTIONS FOR REQUESTING TECHNICAL ASSISTANCE	77
1.6 RECEIPT	77
1.7 GUARANTEE	77
1.8 STANDARDS AND LAWS IN FORCE	78
1.9 SYMBOLS USED IN THIS MANUAL	78
2 TECHNICAL INFORMATION	79
2.1 MAIN PARTS AND GENERAL DESCRIPTION OF THE WINCH	79
2.2 DESCRIPTION OF FUNCTIONS	79
2.3 INTENDED USE	80
2.4 NON-PERMITTED USE	80
2.5 ENVIRONMENTAL CONDITIONS	80
2.6 SAFETY DEVICES	80
2.7 RESIDUAL RISKS	81
2.8 NOISE	81
2.9 ELECTROMAGNETIC FIELDS	81
2.10 TECHNICAL DATA	81
3 SAFETY INFORMATION	82
3.1 GENERAL SAFETY INSTRUCTIONS	82
4 TRANSPORT, HANDLING AND INSTALLATION	83
4.1 MACHINE PACKING	83
4.2 HANDLING - STORAGE	83
4.3 WINCH HANDLING	84
4.4 MOUNTING ON BASE PLATE	84
4.5 INSTALLATION	85
4.6 HYDRAULIC DIAGRAM	87
4.7 CHECKS	87
4.8 INSTALLING THE CABLE	90
4.9 PULLEYS	92

5 START-UP INFORMATION	94
5.1 START-UP.....	94
6 SERVICING INFORMATION	95
6.1 WARNING.....	95
6.2 SERVICING SCHEDULE.....	95
6.3 CABLE.....	95
6.4 GEARBOX LUBRICATION.....	96
6.5 OIL QUANTITY.....	100
6.6 CLEANING.....	101
6.7 DISMANTLING AND DISPOSAL.....	101
7 PROBLEMS AND SOLUTIONS	102
7.1 PROBLEMS, CAUSES AND SOLUTIONS.....	102
8 REPLACEMENT OF PARTS	104
8.1 CABLE REPLACEMENT.....	104
9 ANALYSIS OF RESIDUAL RISKS	106
10 ACCESSORIES	107
10.1 CABLE GLAND (AVAILABLE FOR ALL WINCH SERIES).....	107
10.2 ELECTRIC LIMIT SWITCH.....	107
10.3 SLOW CABLE DETECTOR.....	108
10.4 CABLE GLAND/ELECTRIC LIMIT SWITCH.....	108
10.5 CABLE GLAND/HYDRAULIC LIMIT SWITCH.....	110
10.6 "TER" ELECTRIC ROTARY LIMIT SWITCH.....	112
10.7 "STROMAG" ELECTRIC ROTARY LIMIT SWITCH.....	116
10.8 HYDRAULIC ROTARY LIMIT SWITCH (GCLS).....	118
10.9 LOAD LIMITER WITH STRAIN GAUGE.....	122
10.10 LOAD CELL STRAIN GAUGE LIMITER.....	127
10.11 UNLOCKING THE DRUM WITH MANUAL BALL VALVES.....	130
10.12 UNLOCKING THE DRUM "AUTOMATICALLY".....	134
10.13 AUTOMATIC CABLE GUIDE.....	135
11 NOTES	139

1 GENERAL INFORMATION

1.1 MANUFACTURER'S IDENTIFICATION DATA

DINAMIC OIL S.p.A.

Via Togliatti, 15

41030 Bomporto (MO) – Italy

Telephone: +39 059 812611 – Fax: +39 059 812606

E-mail: dinamicoil@dinamicoil.it

1.2 WINCH IDENTIFICATION DATA



Plate details

- a** = Model.
- b** = Serial number.
- c** = Max. capacity.
- d** = Max. pull.
- e** = Code.
- f** = Year.
- g** = Max. speed.
- h** = Lifting pressure.



Information

The data shown on the identification plate may not be altered under any circumstances.

1.3 USING THIS INSTRUCTION MANUAL

This manual contains the information required for the operator to understand and correctly use the winch. The manual also refers to it as a machine, although Directive 2006/42/EC classifies the winch as partly completed machinery.

The original instructions are provided by the manufacturer in Italian. To fulfil legal or commercial requirements, the original instructions may be supplied by the manufacturer in other languages.

The information contained here is intended for qualified personnel (1).

If there are any doubts concerning the correct interpretation of the instructions, the manufacturer should be contacted for any necessary clarifications.

To make it easier to consult, the manual has been divided into chapters relating to the main concepts.

For quick searches, please use the index.

Reproduction or publication, in whole or in part, of the information contained in this manual without written authorisation from the manufacturer is prohibited.

Using this instruction manual for purposes other than those described without written authorisation from the manufacturer is prohibited.

Any violation will be prosecuted according to the law.

(1) Experienced persons with the correct technical ability, knowledge of regulations and laws, capable of carrying out the necessary operations, and identifying and avoiding potential hazards while handling, installing, operating and servicing the machine.

1.4 EXCLUSION OF LIABILITY

The manufacturer is hereby released of any liability deriving from:

- Incorrect installation or installation which is not in accordance with applicable laws.
- Use of the machine by untrained and/or unauthorised personnel.
- Partial or total disregard of the instructions.
- Lack of servicing.
- Unauthorised alterations or repairs.
- Non-permitted uses.
- Use of non-original spare parts and/or parts that are not specific to the model.
- Environmental circumstances beyond the manufacturer's control.

1.5 INSTRUCTIONS FOR REQUESTING TECHNICAL ASSISTANCE

In the event of machine malfunction or failure requiring technical assistance from a specialist technician, or to request spare parts, contact the manufacturer or reseller directly by phone or fax.

1.6 RECEIPT

If any damages, defects or deficiencies are noted, immediately contact the **Dinamic Oil S.p.A.** Sales Office – Winch Department, tel. +39 059 812611 – fax +39 059 812606.

1.7 GUARANTEE

• **Dinamic Oil S.p.A.** guarantees that its products are free from material or construction defects for the duration of the guarantee period shown on the Dinamic Oil order confirmation at the time of purchase.

• During the guarantee period, **Dinamic Oil S.p.A.** will repair or replace any parts or components that are unserviceable due to ascertained defects in materials or construction. Under this guarantee, any defective pieces must be sent to **Dinamic Oil S.p.A.**, which will examine them so as to determine the cause.

• This guarantee is strictly limited to the repair or replacement of products. - The manufacturer will therefore not accept claims demanding reimbursement for direct or indirect damages of any nature under any circumstance. The merchandise may only be sent once authorised by

Dinamic Oil S.p.A.

- This guarantee does not extend to O-rings or gaskets in general.
- This guarantee does not cover any costs associated with the installation or removal of defective parts from the purchaser's equipment.
- This guarantee does not extend to any products that have been repaired, altered or simply disassembled, even partially.
- This guarantee does not extend to any products that have been subject to misuse, incorrect or careless assembly, or tampering.
- This guarantee, recognised by **Dinamic Oil S.p.A.** through its authorised sellers, excludes and replaces any other guarantee of any nature.

1.8 STANDARDS AND LAWS IN FORCE

The winch has been designed and constructed in accordance with Directive 2006/42/EC and the following reference standards:

ISO 4301/01
FEM 1.001 3rd edition (points 2, 3, 4, 5 and 8)

1.9 SYMBOLS USED IN THIS MANUAL

The following symbols used in the manual highlight operations which are considered safety hazards. It is therefore absolutely essential that the instructions highlighted by these symbols are adhered to.

**Danger**

Information and procedures indicated by this symbol which are not strictly adhered to will result in death or serious injury.

**Attention**

Information and procedures indicated by this symbol which are not strictly adhered to may result in death or severe injury.

**Caution**

Information and procedures indicated by this symbol which are not strictly adhered to may result in minor injury or damage to the machine.

**Information**

Important information or procedures.

2 TECHNICAL INFORMATION

2.1 MAIN PARTS AND GENERAL DESCRIPTION OF THE WINCH

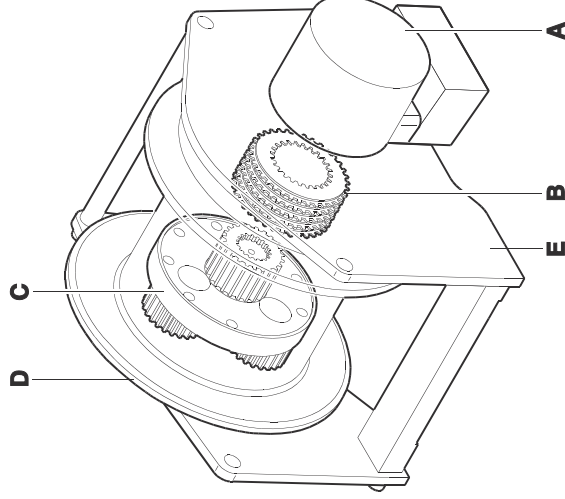
**Legend**

- A** = Hydraulic motor.
- B** = Negative parking brake.
- C** = Planetary gearbox.
- D** = Drum.
- E** = Support structure.

The winch consists of a drum (containing a planetary gearbox and a negative parking brake) driven by a hydraulic motor, with a cable wound around it for lifting loads. The whole unit is installed on a support frame.

2.2 DESCRIPTION OF FUNCTIONS

The winch is controlled by the distributor of the operating machine that it is installed on. The drum rotates to wind and unwind the cable bearing the load. The brake is released when the motor is started and is activated when the motor is stopped.

2.3 INTENDED USE

The winch is designed to lift and lower loads by winding and unwinding the cable around the drum. Using the winch with values greater than those listed in the technical data is considered "improper use" and is therefore "not permitted". Under these circumstances, the manufacturer will accept no liability for any damage caused to persons or objects, and will withdraw any kind of guarantee.

2.4 NON-PERMITTED USE

The winch must never be used to lift or transport people (unless otherwise described in the data sheet).
The winch must never be put into service before the machine that it will be installed on has been declared compliant with the provisions of Directive 2006/42/EC.

2.5 ENVIRONMENTAL CONDITIONS

Ambient temperature for proper use: between $-10\text{ }^{\circ}\text{C}$ and $+40\text{ }^{\circ}\text{C}$, unless otherwise specified in the winch data sheet.

2.6 SAFETY DEVICES

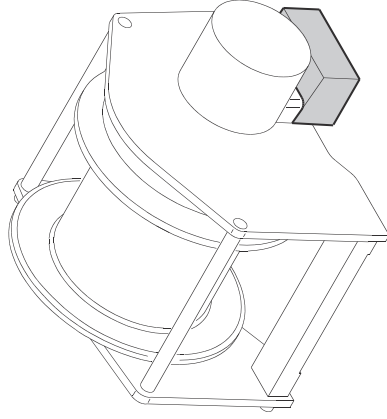

Valve for locking and controlling the lowering operation

This part is hydraulically controlled and fitted directly onto the hydraulic motor, and essential for the winch to function safely. It prevents the load from slipping out of the motor's control while it is being lowered.

2.7 RESIDUAL RISKS

Even if all safety standards have been observed and implemented according to the rules described in this manual, some residual risks may remain. The most recurrent of these include:

- Friction from the cable.
 - Crushing between cable and drum.
 - Inverse rotation of the drum due to human error.
 - Ejection of fluids due to oil leaking under pressure.
- Keep in mind that operating any machine will carry a degree of risk. Every type of operation should be performed with the utmost attention and concentration.

For the complete table of residual risks, see paragraph 9.

2.8 NOISE

The noise levels emitted are not significant.

2.9 ELECTROMAGNETIC FIELDS

In the version of the winch with cable gland/limit switch and load limiter, the electromagnetic emissions are not significant.

2.10 TECHNICAL DATA

The winch technical data can be found in the relevant data sheet provided in the proposal. Please check that the code on the identification plate of the winch is the same on the technical datasheet.

3 SAFETY INFORMATION

3.1 GENERAL SAFETY INSTRUCTIONS

- Read this manual carefully before attempting installation, operation or servicing.
- The user must be familiar with applicable standards on safe working practices and know how to use both the operating machine and the installed winch. The user is responsible for his/her own safety as well as any other persons present in the vicinity of the machine working area.
- All operators must be suitably trained to assemble, use, adjust and operate both the operating machine and the in-stalled winch.
- Do not allow unauthorised personnel to use the machine.
- Do not start or set the machine in motion if it is faulty.
- Do not attempt to locate hydraulic leaks with bare hands; use a piece of paper or wood instead.
- Fluid escaping through a very small hole might be almost invisible, but still capable of penetrating the skin.
- If fluid comes into contact with the skin, seek medical assistance immediately, as there may be risk of infection or skin disease.
- Before removing any caps, plugs or flexible tubes, ensure there is no pressure in the hydraulic circuit.

4 TRANSPORT, HANDLING AND INSTALLATION

4.1 MACHINE PACKING

The machine is packed according to the agreements made with the Customer, taking into account the distance and type of transport chosen.

In general the winches are packed in wooden boxes with joists to facilitate harnessing and lifting.

The packaging varies depending on the quantity of merchandise that it contains.

The weight and dimensions are shown on the transport documents or on the packaging itself.



Attention
Do not tilt or overturn the package while lifting or during transport.

4.2 HANDLING – STORAGE

Use a suitable means of transport to lift and move the packed unit, taking into account the type of packaging. If the package is moved with a fork-lift truck, ensure the weight is balanced on the forks.

If the package is moved with a hoist or hook, ensure the load is balanced in the harness.

Use lifting accessories that are suitable and meet legal standards.

While lifting and positioning the unit, take care not to let it swing too much, to prevent it from hitting something.

The storage area must be protected from atmospheric agents and not be excessively damp or dusty.

The ambient temperature must be between -20°C and $+70^{\circ}\text{C}$ with a maximum humidity level of 90 % with no condensation.

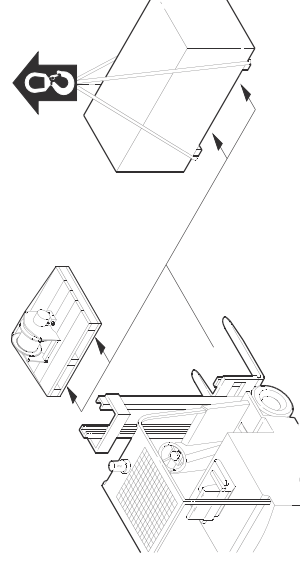

4.3 WINCH HANDLING

For lifting procedures, strap the winch using two belts wrapped around the ends of the drum (fig. A), or attach it at the indicated points (fig. B) if present.

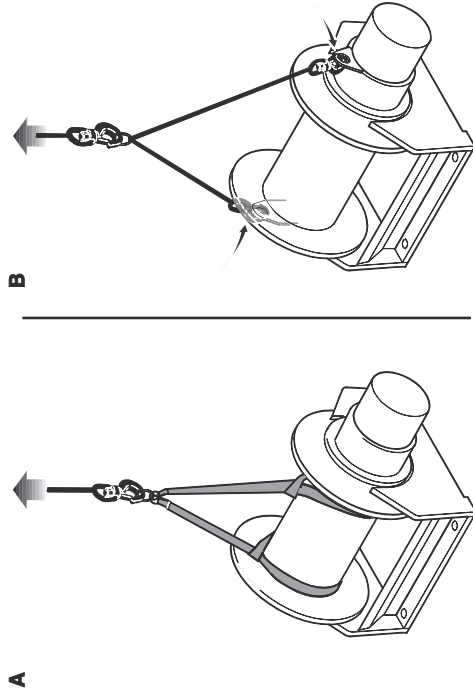

4.4 MOUNTING ON BASE PLATE

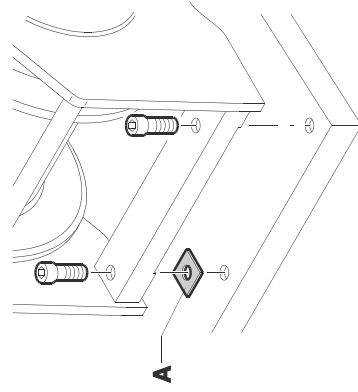

- Ensure that the plate that the winch will be fastened to is flat and sturdy.
- Place the winch on the plate and check that the fastening plates lie perfectly flat on the anchoring surface.
- If one of the winch's weight bearing points is raised from the plate, insert a shim "A" to prevent undue tension in the unit when the screws are tightened.
- Tighten each screw to the correct tightening torque shown in the "Tightening torques" table.

Tightening torques

	Tightening torque values (Nm)		
	Class 8.8	Class 10.9	Class 12.9
M10	50	73	86
M12	86	127	148
M14	137	201	235
M16	214	314	368
M18	306	435	509
M20	432	615	719
M22	592	843	987
M24	744	1060	1240
M27	1100	1570	1840
M30	1500	2130	2500

4.5 INSTALLATION

4.5.1 Warnings



Attention

Winch installation and post-installation checks must be carried out according to applicable legislation in the country where the machine is used.

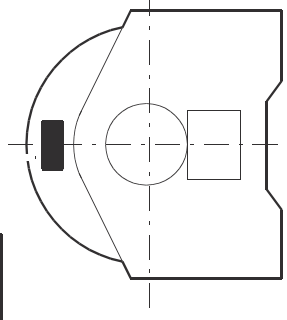

Before mounting, ensure the winding direction of the cable is the same as that shown by the arrow on the winch.
Winches which rotate in the opposite direction to the standard can be supplied on request (anticlockwise).
The winch can be mounted with the anchoring surface facing downwards, upwards or in any other position between the two.

4.5.2 Hydraulic system

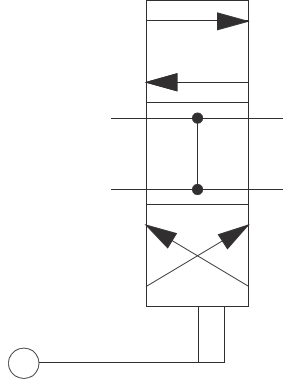
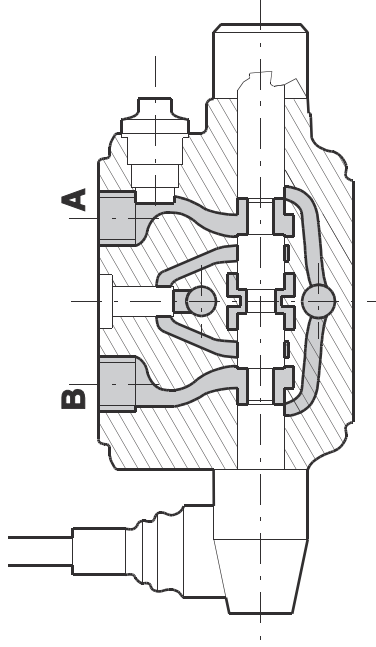

The distributor must have its gate open and be in an "H" configuration.
If the distributor has multiple elements, connect the winch to the last element closest to the outfeed side.
Connect the delivery opening of the element to the winch motor in position "V2".
The hydraulic system must meet the applicable standards and be made with appropriate hoses, filters and valves.

4.6 HYDRAULIC DIAGRAM

Typical hydraulic diagram for winch without accessories

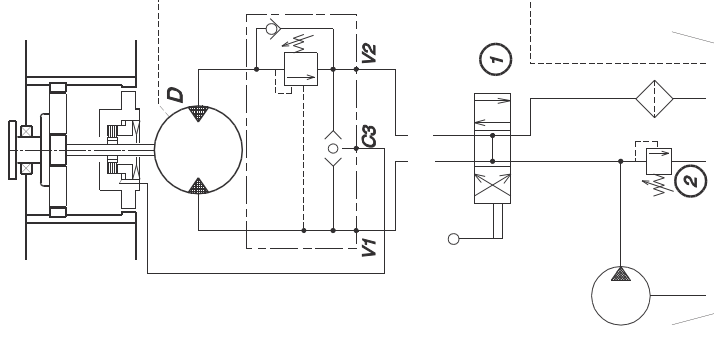

V1 = Lowering line	1 = Distributor with gate open
V2 = Lifting line	2 = Pressure relief valve
C3 = Connection to brake	D = Connection to drainage

4.7 CHECKS

Check the pressure in the return line of the circuit

This measurement should be made by disconnecting the two tubes from the valve and connecting them with a T-piece that has an attachment for a pressure gauge with a maximum scale of 60 bar.



Information

This backpressure must be between 5 and 1 bar.



Caution

Backpressure values higher than 5 bar dangerously restrict the braking torque, and values lower than 1 bar could cause insufficient supply to the motor.

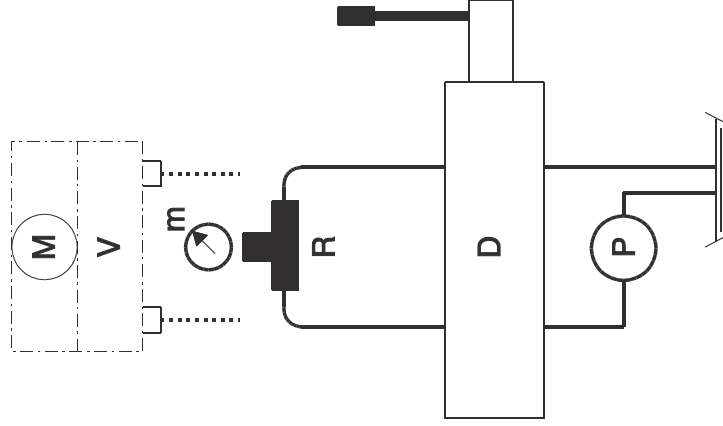

Legend

D = Distributor.

M = Motor.

V = Valve.

m = Pressure gauge.

P = Pump.

R = T-piece.

Hydraulic winches

4 Transport, handling and installation

Ensure the control distributor has its gate open

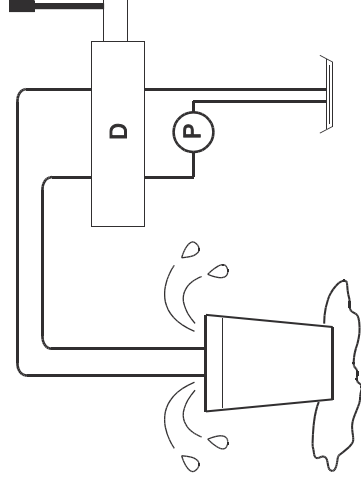
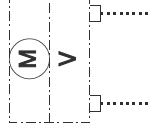

Legend

D = Distributor.

M = Motor.

V = Valve.

P = Pump.

If you do not have safety instructions, you may proceed as follows:

- Disconnect the tubes from the valve and place their ends in a container large enough for the purpose. Start the pump while keeping the distributor in the centre.
- If the two tubes do not release oil into the container, the distributor has its **gate closed**. If the two tubes do release oil, the **gate is open**.

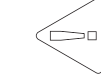

Caution

Ensure the oil flow does not cause the container to overflow, wasting oil and releasing polluting substances into the environment. If there is a risk of this occurring, stop the test immediately and only resume once the container has been replaced with a larger one.

Hydraulic winches

4 Transport, handling and installation



Information

Do not release used oil into the environment. Collect it and send it to authorised centres for disposal.

4.8 INSTALLING THE CABLE

Installing the cable with a thimble



Attention

The winding direction of the cable must be the same as the drum rotation direction shown by the arrow.
Ensure that the emergency switch is working and that a skilled operator is on hand and ready to stop the winch in the event of entangling or other irregularities that could cause harm to the operator in the vicinity of the cable.

If the cable is not sufficiently compact during the initial mounting phase, it may get caught up in the coils underneath and damaged when load is applied to it.

- 1) Place the end of the cable into the slot on the drum and then into the pocket "A".
- 2) Fold the cable around the thimble "B". Then secure the cable and thimble in the slot by pulling firmly.

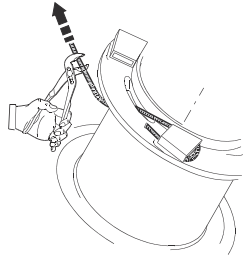
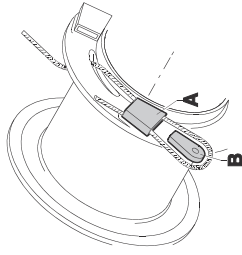

Installing the cable with clamps



Attention

The winding direction of the cable must be the same as the drum rotation direction shown by the arrow.
Ensure that the emergency switch is working and that a skilled operator is on hand and ready to stop the winch in the event of entangling or other irregularities that could cause harm to the operator in the vicinity of the cable.

If the cable is not sufficiently compact during the initial mounting phase, it may get caught up in the coils underneath and damaged when load is applied to it.

- 1) Place the end of the cable in the slot on the edge of the drum and then into the clamps "A". The protrusion "B" from the final clamp must be at least twice the diameter of the cable.
- 2) Tighten the clamp screws by the same amount.

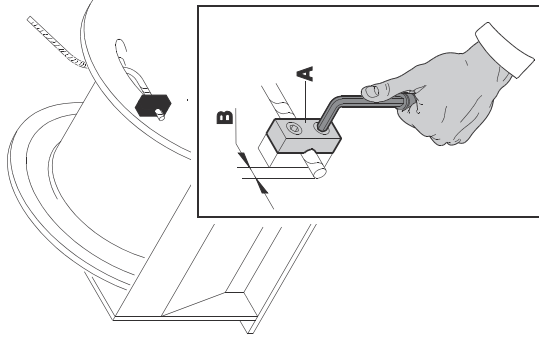

For the cable to wind correctly, a preload of 5 % of the cable's breaking load is required. The breaking load varies depending on the cable's diameter and type, and must be indicated by the supplier on the cable's certificate.

4.9 PULLEYS

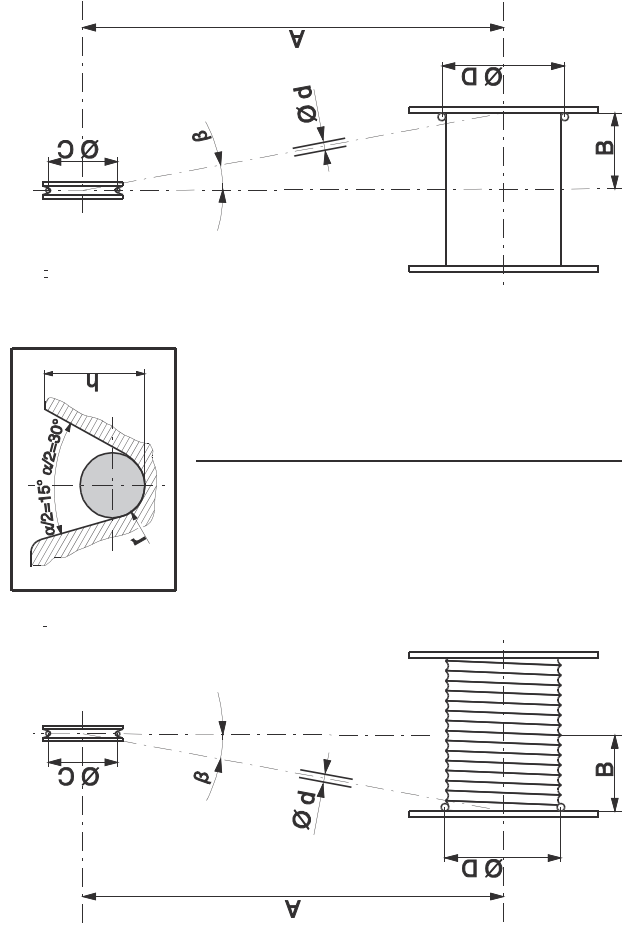

Legend

- H** = Depth of groove.
- a** = Angle between the sides of the groove.
- d** = Nominal diameter of the cable.
- 1** = Maximum angle "b":
 - smooth drum = 1°30' (tg b = B/A)
 - threaded drum = 2° (tg b = B/A)
- 2** = Groove radius "r" = 0,5375 x d.
- 3** = Groove minimum height "h" = 2 x d.
- 4** = Angle between the pulley grooves "a" = between 30° and 60°.

Diameters to be chosen according to mechanism classification

Mechanism classification	Drums h1 = D/d	Pulleys h2 = C/d
M1	11,2	12,5
M2	12,5	14,0
M3	14,0	16,0
M4	16,0	18,0
M5	18,0	20,0
M6	20,0	22,4
M7	22,4	25,0
M8	25,0	28,0

The pitch diameter of the return pulley must comply with the ISO 4308-1 standard, according to the mechanism classification.

Example:

For a mechanism classification of M5, the ratio between the pitch diameter of the pulley and the diameter of the cable must be no lower than 20.

5 START-UP INFORMATION

5.1 START-UP

Safety instructions

Danger

Before work commences, signs or other appropriate measures must be in place to warn users that it is forbidden to approach or remain in the danger zone due to loads being lifted. A danger warning plate must be placed on the machine informing users of the danger presented by the running cables wrapped around the pulleys and drum, and forbidding anyone from approaching the moving parts. This plate must be reproduced in the user manual of the crane or the operating machine that it is installed on.



- Check the condition of the lifting parts (cable, hook, etc.) before using the winch.
- When carrying out start-up operations, the operator and any other team members must remain a safe distance from the cable, to avoid injury in the event of it breaking.
- The first few lifting operations should be carried out with a modest load no more than 1 metre from the ground, to check that the lowering operation is controlled.
- Carry out manoeuvres gradually, avoiding sudden movements and swinging.
- Bring the winch to its limit position and gently push the distributor lever to purge any air from the system.

6 SERVICING INFORMATION

6.1 WARNING



Attention

Ensure that the machine that the winch is installed on is stopped and cannot be started while being serviced.

6.2 SERVICING SCHEDULE

Operation	Frequency			Chapter in manual
	8 hours	250 hours	500 hours	
Cable inspection	•			6.3
Oil level check		•		6.4
Cable lubrication		•		6.3
Screw tightness check		•		4.4
Gearbox oil change			•(*)	6.4

(*) Carry out the first change after 500 working hours, and then once per year.

6.3 CABLE

Cable inspection

- Check the condition of the cable carefully, along its en-tire length. If it has any dents, crushed sections, bulges or a number of broken strands, it must be replaced with a cable of the same specifications and length.
- Replace the cable when its nominal diameter has re-duced by 10 % due to wear or the elementary strands breaking.
- Replace the cable when corrosion or any kind of warp-ing occurs.
- Replace the cable when the lead coating on the cable lug is damaged.

Cable lubrication

- Clean the cable to remove any traces of dirt, dust or sand.
- To reduce corrosion, lubricate the cable with a specialist product.

6.4 GEARBOX LUBRICATION

6.4.1 Oil level check and change

(winch series NP - NPA - A - S - SE - SW - SF)

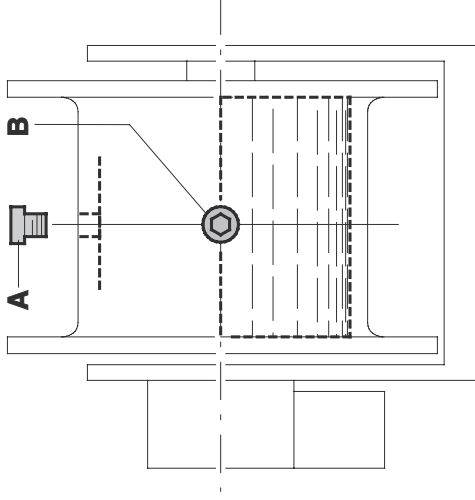

Information

Do not release used oil into the environment. Collect it and send it to authorised centres for disposal.

Unwind the cable until filling cap "A" and level cap "B" are visible. If the oil level is low, top up through the hole in cap "A" until oil escapes from the hole in cap "B" (in horizontal position). For oil types, see section "6.5 Oil quantity".

To change the oil:

- Place a container under the winch to collect the used oil.
- Turn the drum so that the oil level hole is at the bottom.
- Completely drain the oil.
- Turn the drum so that the level hole is on the horizontal axis and the filling hole is at the top.
- Add oil through the filling hole until it flows out of the level hole.
- Refit level cap "B" and filling cap "A".

6.4.2 Oil level check and change

(winch series SR - SWR - SFR)

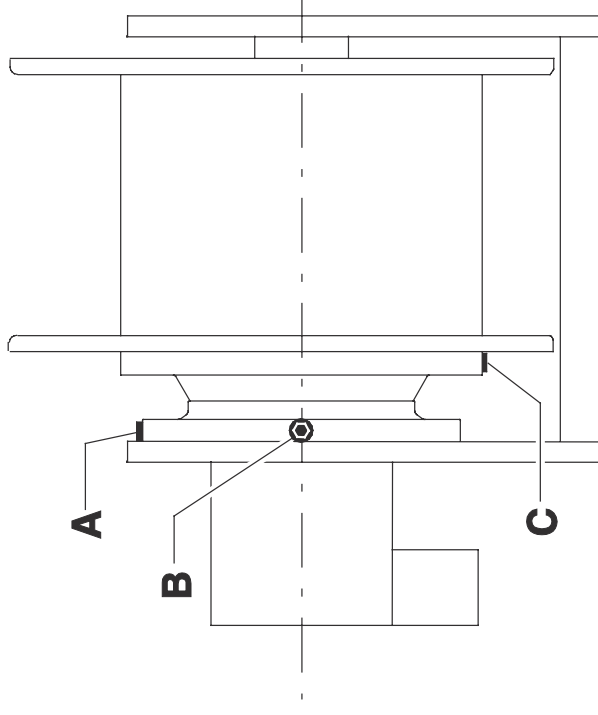

Information

Do not release used oil into the environment. Collect it and send it to authorised centres for disposal.

If the oil level is low, top up through the hole in cap "A" until oil escapes from the hole in cap "B" (in horizontal position). For oil types, see section "6.5 Oil quantity".

To change the oil:

- Place a container under the winch to collect the used oil.
- Turn the drum so that the oil drain hole "C" is at the bottom.
- Completely drain the oil.
- Close the drain hole "C" with the appropriate cap.
- Add oil through the filling hole until it flows out of the level hole.
- Refit level cap "B" and filling cap "A".

6.4.3 Oil level check and change

(winch series S - SE)

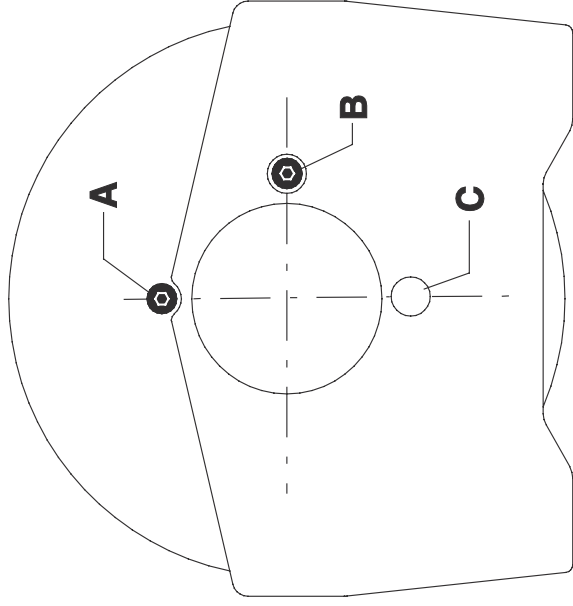

Information

Do not release used oil into the environment. Collect it and send it to authorised centres for disposal.

If the oil level is low, top up through the hole in cap "A" until oil escapes from the hole in cap "B" (in horizontal position). For oil types, see section "6.5 Oil quantity".

To change the oil:

- Place a container under the winch to collect the used oil.
- Turn the drum so that the oil level hole is at the bottom "C".
- Completely drain the oil.
- Turn the drum so that the hole of level cap "B" is on the horizontal axis and the hole of filling cap "A" is at the top.
- Add oil through the filling hole until it flows out of the level hole.
- Refit level cap "B" and filling cap "A".

6.4.4 Oil level check and change

(winch series SRD - SWD - WDD)

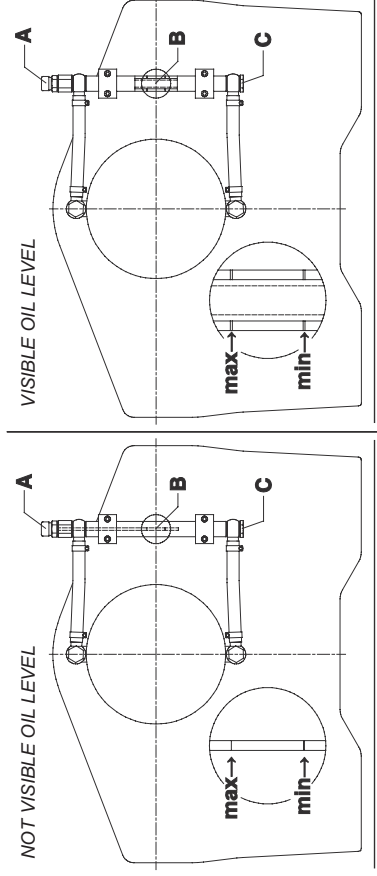

Information

Do not release used oil into the environment. Collect it and send it to authorised centres for disposal.

If the oil level is low, top up through the hole in cap "A" until the oil reaches the level "B" between the min. and max. indicators. For oil types, see section "7.5 Oil quantity".

To change the oil:

- Place a container under the winch to collect the used oil.
- Remove cap "C" and drain the oil completely.
- Add oil through the filling hole "A" until the oil reaches the level "B" between the min. and max. filling indicators "A" above.
- Refit cap "A".

6.4.5 Gearbox lubrication with grease (winch series P)

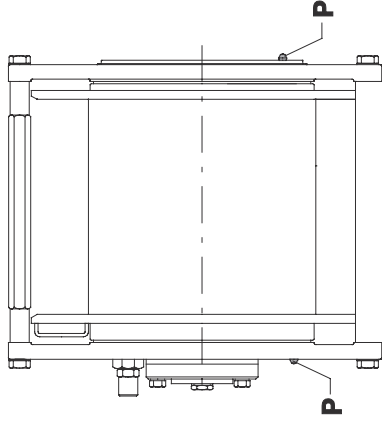

The winch must be greased on the gears fitted inside the drum and on the drum guide rings. For the lubrication, use Renbrand EP/2 - Q8 lithium gear grease or equivalent. After every 250 hours of operation, grease the internal parts of the drum using the lubricators "P" located on the supports.

6.5 OIL QUANTITY

The following table contains the quantities of oil (in litres) for the main series of winches in the catalogue.

Series	Oil type HLP ISO VG 46	Series	Oil type ISO VG 150
NP05-NP10-NP12	0.6	SE20/3 V-SE25/3 V-SE27/3 V	3.5
NPA18-NPA19	1.2	SE30V-SE35V	6
A30	0.8	S45V/2	7
A44	1.2	SE45V	9.5
A60	1.4	SRD A60	2.5
A80	3.5	SRD B80	4.5
S15-S19	1	SRD C100	4
S20-S25-S27	1.7	SRD D120	5
S30/2-S35/2	3.5	SRD E150	7
S45/2	6	SRD F180	10
SE20/3-SE25/3-SE27/3	3.5	SRD G230	14
SE30-SE35	6		
SE45	9.5		

6.6 CLEANING



Attention

Clean the winch with detergents that comply with applicable standards. In order to prevent damage, do not point the jet at the electrical equipment when washing with liquid under pressure.

6.7 DISMANTLING AND DISPOSAL

The machine must be dismantled by technically specialist, qualified personnel with the required knowledge of hydraulics and mechanics. Components must be separated according to the materials they are composed of and sent to authorised collection centres. In accordance with the WEEE Directive (Waste Electrical and Electronic Equipment), the electrical and electronic parts, marked with the relevant symbol, must be disposed of at authorised collection centres.

7 PROBLEMS AND SOLUTIONS

7.1 PROBLEMS, CAUSES AND SOLUTIONS

In the event of the winch malfunctioning, please refer to the table below to identify the problem, its cause and possible solutions.
If the problem persists, contact one of the Manufacturer's authorised workshops.

Problem	Possible cause	Solution
Noise in the hydraulic circuit	Presence of air in the circuit	Purge the circuit
Noise while lifting without loads, accompanied by jerky rotation	Insufficient circulation of oil in the circuit	Lift gradually increasing loads until the winch rotates normally and the noise disappears. If this happens, increase the quantity of oil in the circuit. If this is not possible, contact the manufacturer's technical office.
		ATTENTION!!! Insufficient circulation may be caused by prolonged choking of the oil flow by the operator manoeuvring the lever of the distributor. This is dangerous
The load being lowered tends to fall	Impurities in the valve	Remove the valve and clean it. Check the circuit filter cartridge and replace it if necessary.
	Cable wound in opposite direction to that shown by the arrow	Wind the cable in the direction shown by the arrow (see paragraph 4.5)
	Excessively high backpressure	Connect the motor drain hole directly to the tank
With the distributor set in the centre, the load tends to lower	Brake springs are broken	Replace the springs. This should be done at an authorised workshop or by the manufacturer.

Load cannot be lifted

Insufficient pressure in the hydraulic circuit	Ensure the pressure relief valve on the control distributor is set correctly.
	Check the motor drainage. If the oil flow exceeds 1 litre per minute, replace the motor.
Damaged motor	

8 REPLACEMENT OF PARTS

8.1 CABLE REPLACEMENT

The cable must always be replaced when:

- It has a number of broken strands (approximately 10 %).
- It is permanently warped (reduction in cross section, dented, squashed, etc.).
- The lead coating on the cable lug is damaged.
- Corrosion or any kind of warping occurs.

Removing the cable with a thimble

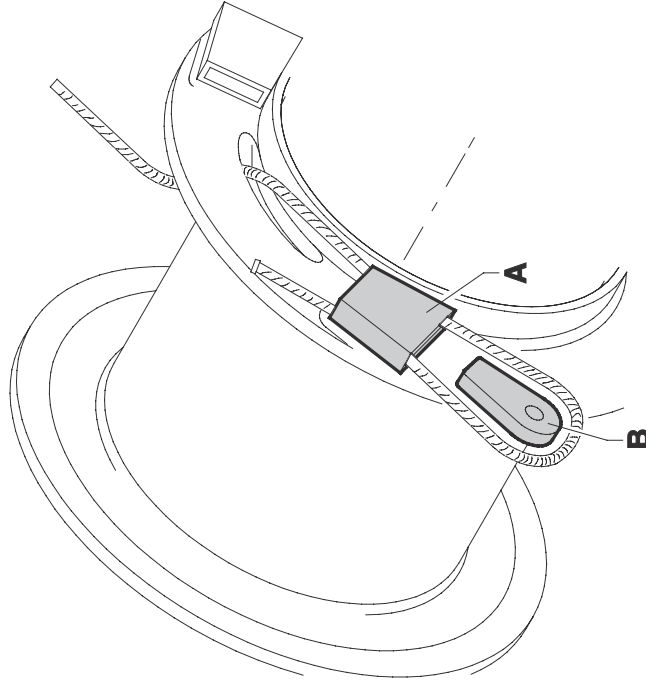

- 1) Completely unwind the cable.
- 2) Remove the cable and thimble "B" from pocket "A".
- 3) Unthread the cable.

Installing

See paragraph 4.8 "Installing the cable".

Hydraulic winches

8 Replacement of parts

104

Removing the cable with clamps

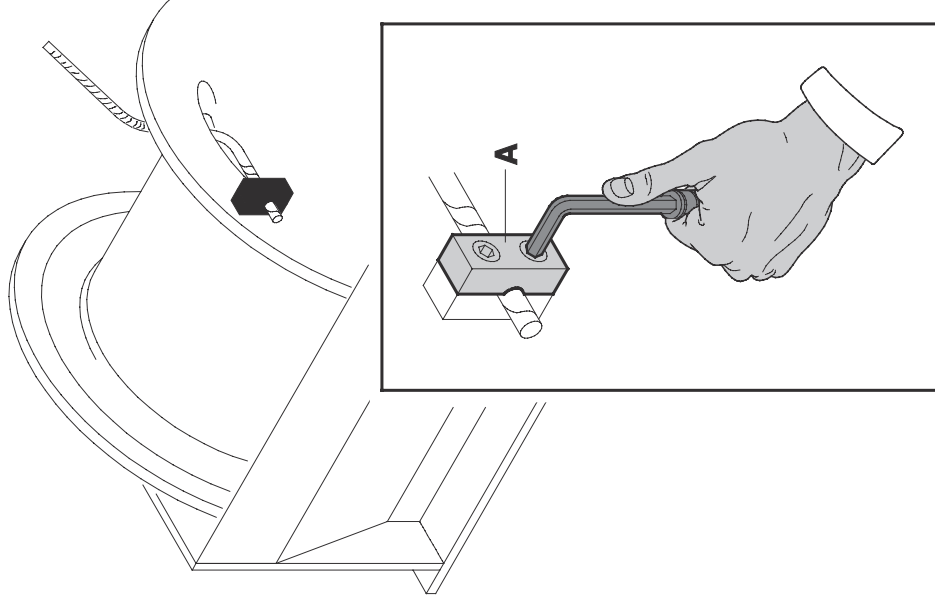

- 1) Completely unwind the cable.
- 2) Loosen the clamp screws "A".
- 3) Unthread the cable.

Installing

See paragraph 4.8 "Installing the cable".

Hydraulic winches

8 Replacement of parts

105

9 ANALYSIS OF RESIDUAL RISKS

Note	Directive 2006/42/CE Annex I	Description	Remarks
18	1.3.3	Risks due to falling or flying objects	The operation and servicing manual explains how to unpack and handle winches. The customer is responsible for taking these instructions into account while handling.
19	1.3.4	Risks posed by surfaces, edges or angles	The customer is responsible for protecting the operator from risks due to rough surface edges or corners during installation.
22	1.3.7	Risks related to moving parts	The customer is responsible for protecting the operator from potential risks related to moving parts
23	1.3.8	Choice of protection against risks arising from moving parts	The customer is responsible for protecting the operator from potential risks related to moving parts
25	1.4.1	General requirements for guards and protective devices	The customer is responsible for choosing the requirements for guards and protective devices
26	1.4.2.1	Fixed guards	The customer is responsible for fitting any fixed guards
28	1.4.2.3	Adjustable guards restricting access	The customer is responsible for fitting any adjustable guards restricting access
29	1.4.3	Special requirements for protective devices	The customer is responsible for choosing the requirements for guards and protective devices

10 ACCESSORIES

10.1 CABLE GLAND (available for all winch series)

This device presses the cable onto the drum, so that it can be wound more effectively. There are no adjustments to be made to this device.

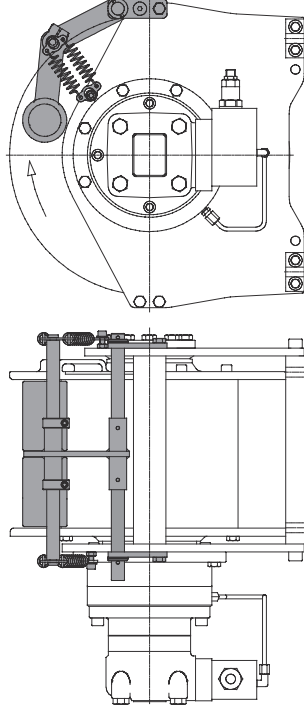

10.2 ELECTRIC LIMIT SWITCH

(available for all winch series)

This safety device can detect the maximum winding of the cable (excluding the 4+5 coils which are always compulsory), using an electric microswitch. The signal from the microswitch can be used to stop the machine.

Adjusting the cable gland/limit switch

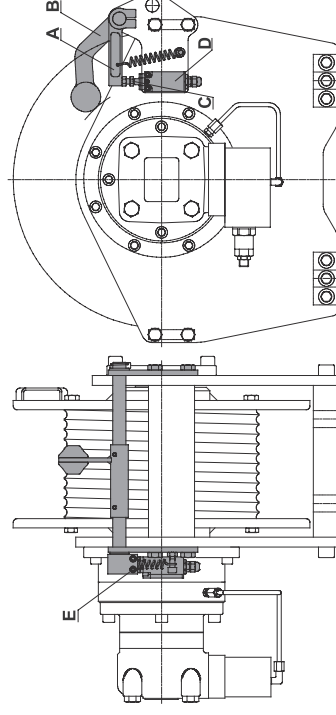

- 1) Loosen screws "C" and "E".
- 2) Place levers "A" and "B" in the desired position.
- 3) Adjust screw "C" until it excites microswitch "D".
- 4) Loosen screws "C" and "E".

10.3 SLOW CABLE DETECTOR

(available for all winch series)

This device can detect when the cable is slow, using an electric microswitch. The signal from the microswitch can be used to stop the machine.

Adjusting the slow cable detector

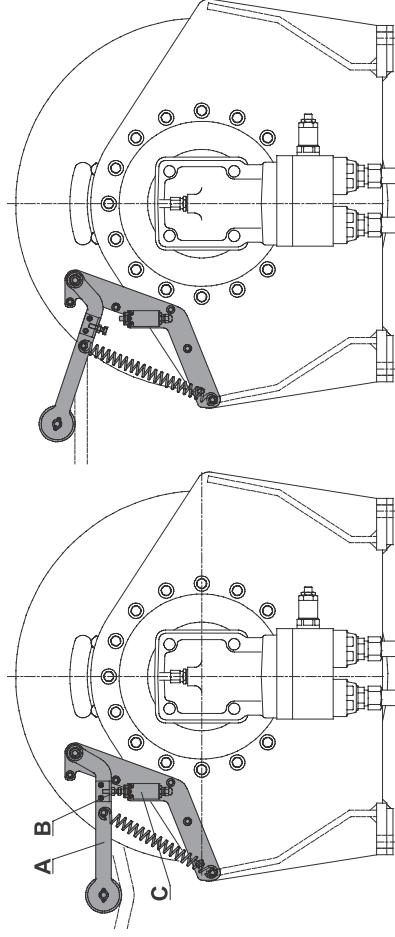

- 1) Put lever "A" into the desired position.
- 2) Adjust screw "B" until it excites microswitch "C".
- 3) Tighten screw "B".

10.4 CABLE GLAND/ELECTRIC LIMIT SWITCH

(available for all winch series)

This safety device can detect the maximum winding of the cable (excluding the 4-5 coils which are always compulsory), using an electric microswitch. It also presses the cable onto the drum so that it can be wound more effectively.

The signal from the microswitch can be used to stop the machine.

Adjusting the cable gland/limit switch

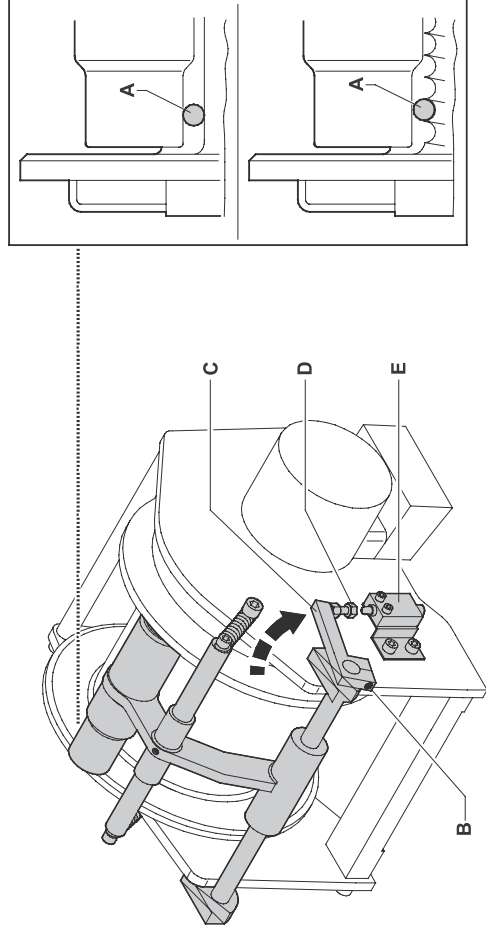

Information

Carry out the operation with the cable completely unwound.

- 1) Insert a shim "A" with the same diameter as the cable under the roller end.
- 2) Loosen screw "B".
- 3) Turn lever "C" until screw "D" excites microswitch "E".
- 4) Tighten screw "B".

Typical hydraulic diagram for winch with cable gland/electric limit switch

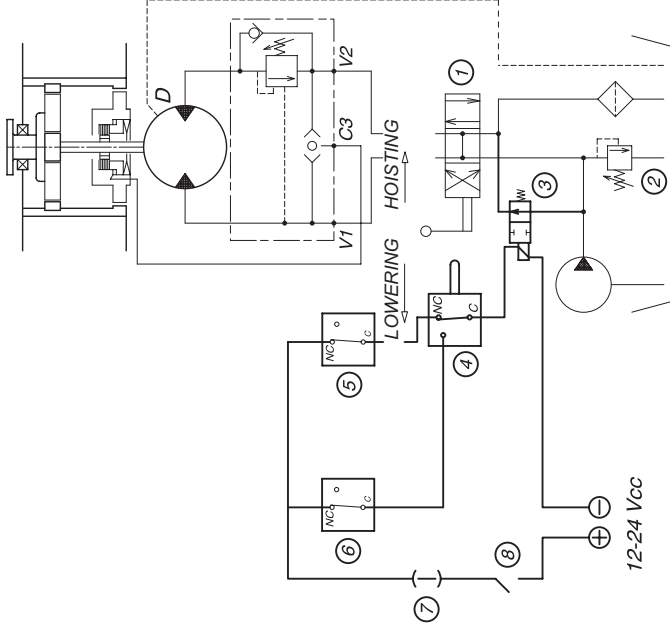

V1	= Lowering line	3	= Discharge activation solenoid valve NO
V2	= Lifting lin	4	= Reset microswitch
C3	= Connection to brake	5	= Lifting stroke limit microswitch
D	= Connection to drainage	6	= Lowering stroke limit microswitch
1	= Distributor with gate open	7	= Fuse
2	= Pressure relief valve	8	= Limit switch activation key

10.5 CABLE GLAND/HYDRAULIC LIMIT SWITCH

(available for all winch series)

This safety device can detect the the maximum winding of the cable (excluding the 4-5 coils which are always compulsory), using a hydraulic microswitch. It also presses the cable onto the drum so that it can be wound more effectively.

The signal from the microswitch is used to stop the machine, and the system is completely automatic.

Adjusting the cable gland/limit switch

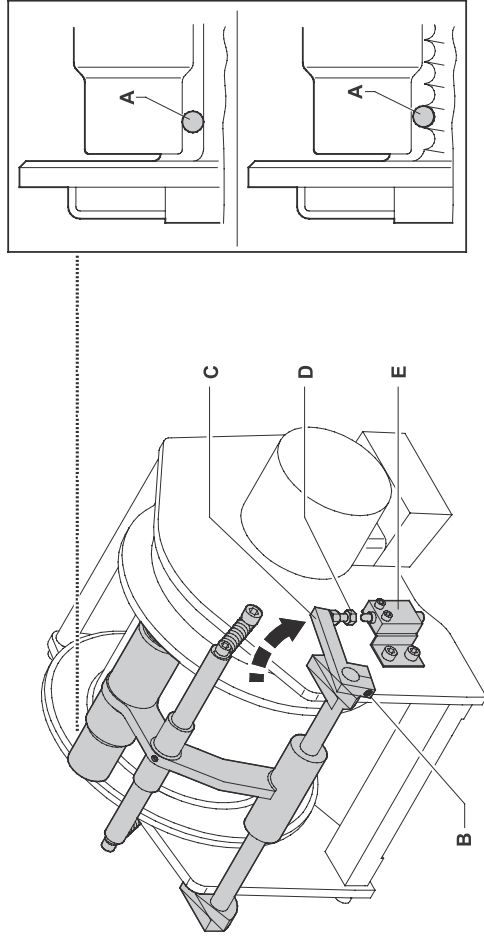

Information

Carry out the operation with the cable completely unwound.

- 1) Insert a shim "A" with the same diameter as the cable under the roller end.
- 2) Loosen screw "B".
- 3) Turn lever "C" until screw "D" excites microswitch "E".
- 4) Tighten screw "B".

Typical hydraulic diagram for winch with cable gland/hydraulic limit switch

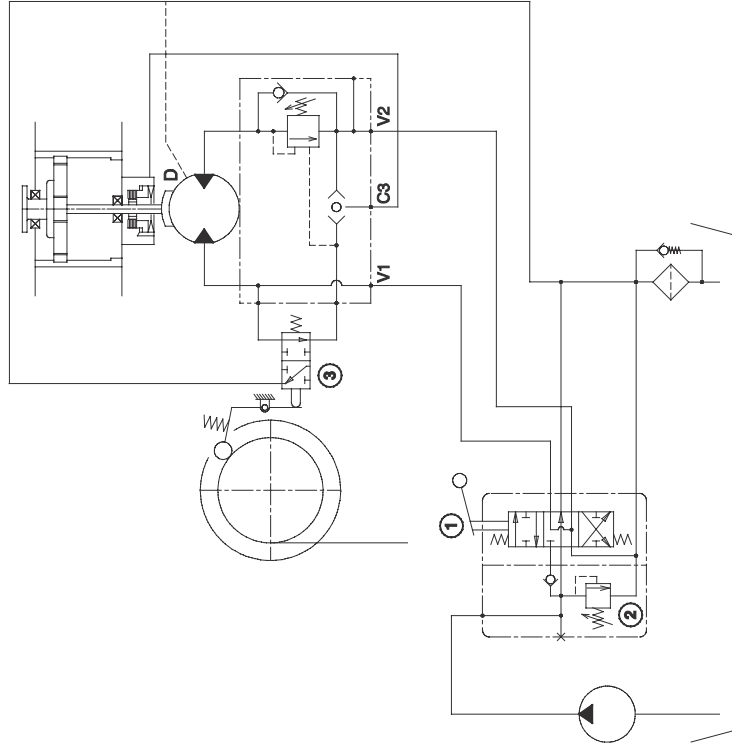

V1	= Lowering line
V2	= Lifting line
C3	= Connection to brake
D	= Connection to drainage

1	= Distributor with gate open
2	= Pressure relief valve
3	= Lower limit position hydraulic valve

10.6 "TER" ELECTRIC ROTARY LIMIT SWITCH

(only available for series S, SE, SW, SF and SFR winches)

This device is used to control the winch's movement. After a set number of turns, the cams operate the electric switches, starting the predetermined movement. It is commonly used as an upper and lower limit switch.

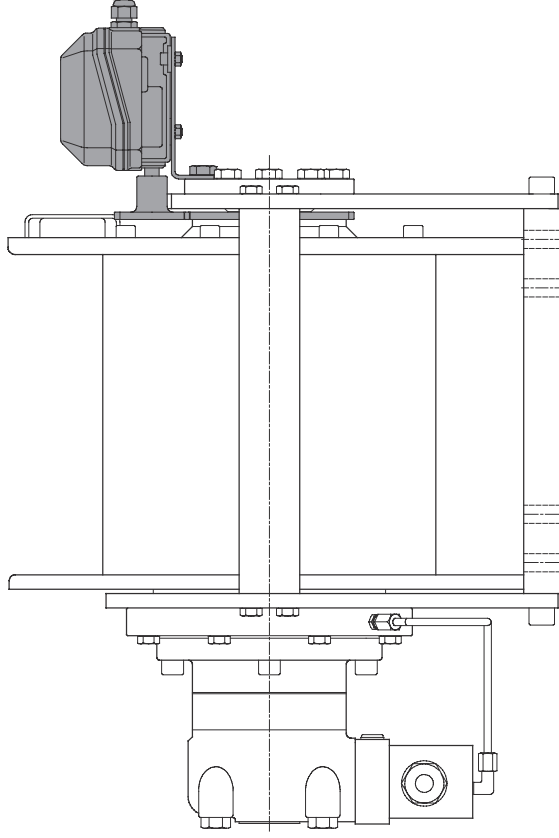

Operation, servicing and adjustment

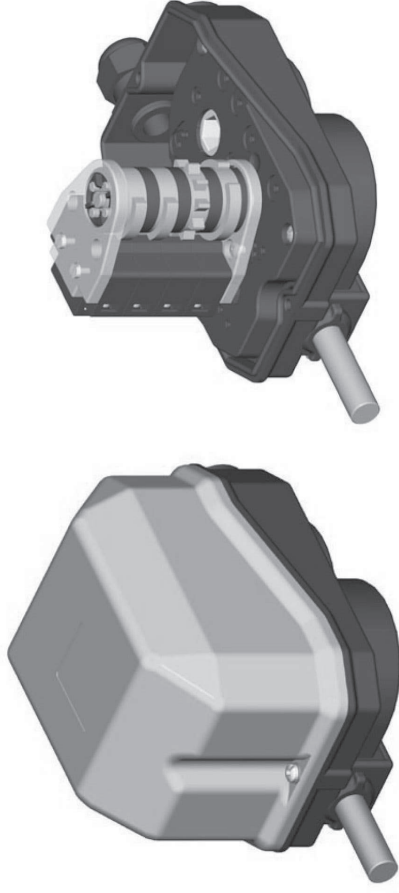

The limit switch is designed to be used in an industrial environment, even in harsh climatic conditions (temperatures ranging from $-25\text{ }^{\circ}\text{C}$ to $+70\text{ }^{\circ}\text{C}$, and suitable for use in tropical environments). The device is not suitable for use in environments with potentially explosive atmospheres, corrosive agents or a high percentage of sodium chloride (saline mist). Contact

with oils, acids and solvents may damage the device. The limit switch must be fastened using appropriate feet or an appropriate flange (47). Misalignments between the limit switch shaft (54, 61) and the gearbox shaft that it is connected to must be eliminated. For this reason, it is advisable to use appropriate couplings (49, 51), flexible shafts or appropriate drive systems (not supplied as standard). The operating point of the cams (08) must be adjusted using the relevant screws (09, 10, 12, 13) after the the central screw (03) has been loosened. Tighten the central screw (03) once the adjustment has been made. The switches (07) are used as an auxiliary control for contactors or electromagnetic loads in general (utilisation category AC-15 according to EN 60947-5-1). The switches (07) have con-tacts with positive opening operation (EN 60947-5-1). Connecting more than one phase to each switch (07) is not recommended. Do not oil or grease the control elements (08) or the switches (07). To facilitate electric wiring, the set of cams/switches (35) can be removed from the limit switch by loosening the fastening screws (15) on the base. Do not loosen the screws (01) located on the upper section of the set of cams/switches to avoid removing the individual elements of the pack itself. Once wiring has been completed, the set of cams/switches (35) must be put back and cor-rectly screwed in place, taking care to couple the plastic hexagonal bushings (14, 38). The limit switch must be in-stalled by skilled, qualified personnel. The electric wiring must be performed professionally and in accordance with regulations in force. Before the limit switch is installed and serviced, the machine's main power supply must be switched off.

Correctly installing the limit switch

- Remove the cover (33), unscrewing the fastening screws (32).
- Join the limit switch shaft (54, 61) to the gearbox shaft, ensuring the two shafts are not misaligned. It is advisable to use couplings (49, 51), flexible shafts or appropriate drive systems.
- Securely fasten the limit switch to prevent the device from vibrating abnormally during operation. Only use feet or the flange (47) to fasten it. Insert the multipolar cable into the limit switch using the appropriate cable gland (41).
- Strip the multipolar cable so that it is the right length to make the electrical connection to the switches (07).
- Tape the stripped part of the multipolar cable.
- Clamp the cable in the cable gland (41).
- Make the electrical connections to the switches (07), adhering to the contacts diagram shown on the switches them-selves. Tighten the screws to a torque of 0.8 Nm; clamping capacity of the terminals 1×2.5 mm² - 2×1.5 mm² (UL - (c)UL: 60 °C or 75 °C copper conductors (Cu) with AWG 16-18 rigid or soft cable).
- Adjust the operating point of the cams (08). To make the correct adjustment, loosen the central screw (03) of the cam pack, adjust the operating point of each individual cam (08) with its adjustment screw (09, 10, 12, 13) (numbered screws indicate the cams in ascending

order from the bottom to the top of the pack), then tighten the central screw (03).

- Close the limit switch again, taking care to correctly position the rubber (34) on the inside of the cover (33).

Periodic servicing

- Check that the screws (32) on the cover (33) are well tightened.
- Check that the screws on the switch terminals (07) are well tightened.
- Check that the central fastening screw (03) on the cams (08) is well tightened.
- Check that the wiring is in good order (especially in the clamping area on the switch).
- Check that the front (52) and rear (42) bearing covers are positioned correctly.
- Check the condition of the rubber (34) on the inside of the cover (33) and that the cable gland (41) is properly clamping the multipolar cable.
- Check that the limit switch's casing (33, 43, 44) is not damaged.
- Check that the limit switch (54, 61) and the gearbox shaft are correctly aligned.
- Check that the limit switch is properly fastened.

Any changes made to the limit switch's components will invalidate the values on the device's registration plate and identification, and invalidate its guarantee. If any of its parts need to be replaced, only original spare parts may be used.

TER will not accept any liability for any damage resulting from the device being used improperly or installed incorrectly.

Technical specifications

Compliant with Community Directives: 2006/95/EC and 2006/42/EC
Compliant with Standards: EN 60204-1, EN 60947-1, EN 60947-5-1 and EN 60529

Storage ambient temperature: between -40 °C and +70 °C

Operating temperature: between -25 °C and +70 °C

Protection rating: IP65

Appliance class: Class II

Cable inlet: M20 cable gland

CE marking

Technical specifications of switches

Utilisation category: AC-15

Nominal utilisation current: 3 A

Nominal utilisation voltage: 250 V

Nominal thermal current: 10 A

Nominal isolation voltage: ~300 V

Mechanical duration: 1×106 operations

Terminal identification: according to EN 50013

Terminal connection: with self-lifting clamping screw

Clamping capacity: 1×2.5 mm², 2×1.5 mm²

(UL - (c)UL: 60 °C or 75 °C copper conductors (Cu) with AWG 16-18 rigid or soft cable)

Tightening torque: 0.8 Nm

CE marking

For more information, please visit: <http://www.terinternational.net/home.php>

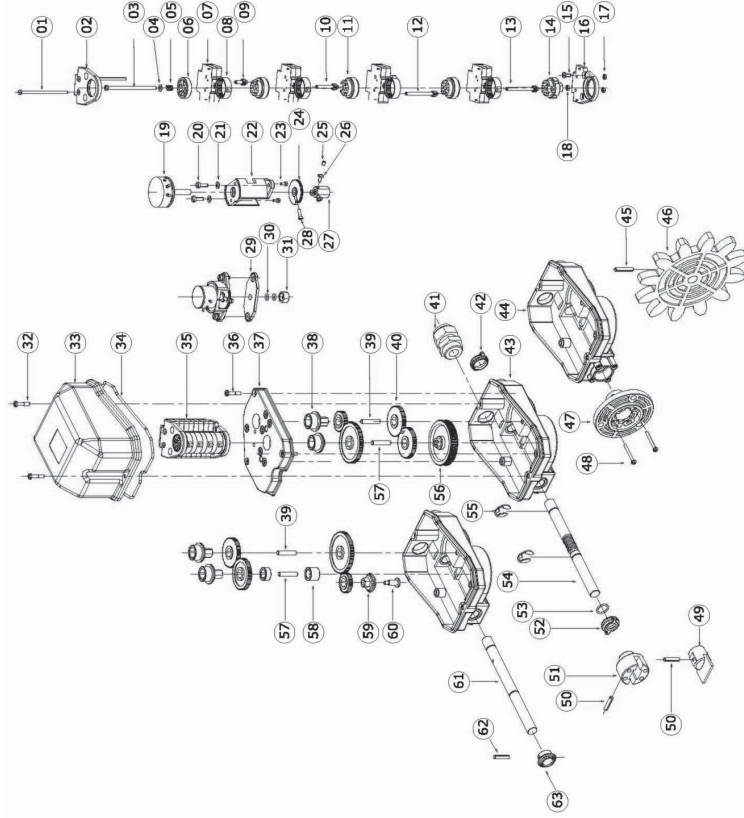

10.7 “STROMAG” ELECTRIC ROTARY LIMIT SWITCH

(only available for series S, SE, SW, SF, SFR, SRD, SWD and WDD winches)

This device is used to control the winch's movement. After a set number of turns, the cams operate the electric switches, starting the predetermined movement. It is commonly used as

an upper and lower limit switch.

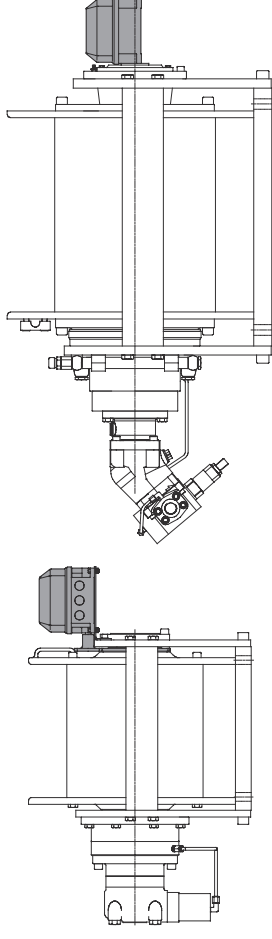

Operation, servicing and adjustment

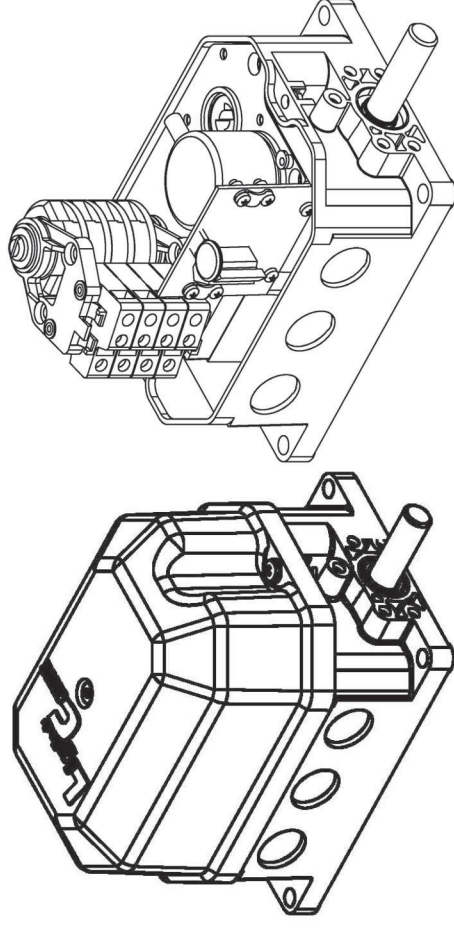

Construction of the geared cam limit switch

The geared limit switch consists of a gearbox and switch combination which are located within a housing. The torque is positively transmitted from the input shaft to the switching shaft and, when using the precise adjustment “FV” of the cam discs, it is also transmitted up to the contact. The gear housing is made of glass fiber reinforced synthetic material, the cap is not reinforced. Mounting as required.

Protection IP 65 to DIN VDE 0470 – 1/EN 60529.

The continuous service temperature is –25°C to +80°C.

At 3 sides the housing is provided with pre – cut holes for cable entries which can be opened by the customer if necessary.

For fixing of the cable entries, insert fixing nuts. These nuts are protected against torsion. The

thread lengths of the required glands are stated on the dimensional drawing.

The housing is provided with formed feet. If required, an additional flange can be screwed to the shaft input.

Contact connections

The standard contact 99 has glands for 2 x 1.5 mm² cables.

In the particular case the utilisation of switching contacts with flat plugs 6.3 x 0.8 mm is possible. Caution!

With connection voltages exceeding 25 VAC or 60 VDC, insulated flat plugs only must be used.

Cam discs

The cam discs are provided with 40_ contact cams as standard. On request cam discs with any other cam angle can be provided at extra charge. Special cam discs are already made in our works as per the customer's specification.

For more information, please visit:

<http://www.stromag.com/produkte/endschalter/schneckengetriebe/schneckengetriebe-gkn-stromag-lightcam.html>

10.8 HYDRAULIC ROTARY LIMIT SWITCH (GCLS)

(only available for series SRD, SWD and WDD winches)

This device is used to control the winch's movement. After a set number of turns, the cams operate the hydraulic switches, starting the predetermined movement. It is commonly used as an upper and lower limit switch. The system is completely automatic.

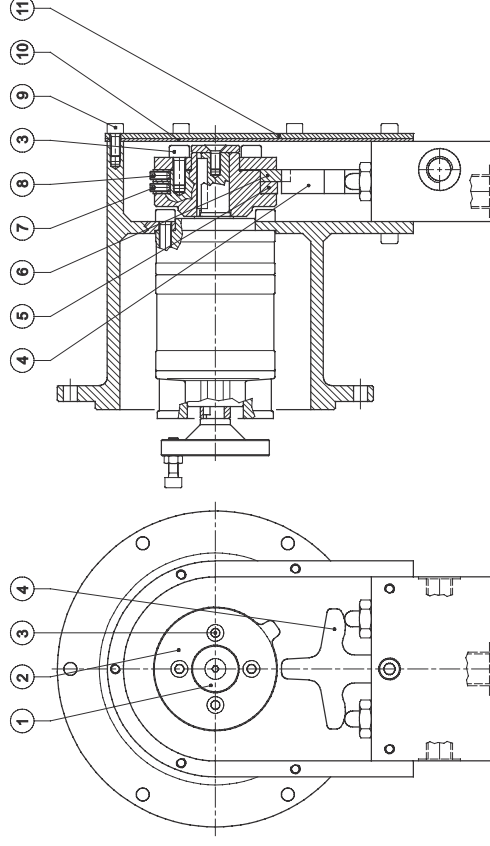
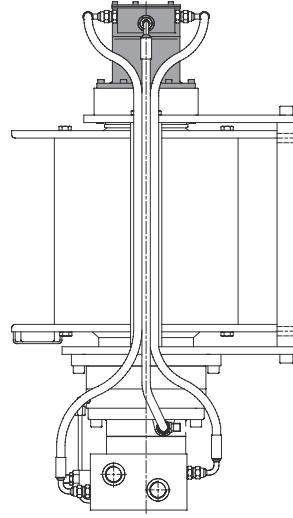

Adjusting the hydraulic rotary limit switch

1) Take out the screws (9), remove the cover (11) and the gasket (10).

2) Loosen the screws (3) and grub screws (7 and 8)

Turn the winch drum in the direction to lift the load, and check that the cams are rotating in the right direction (5 and 6).

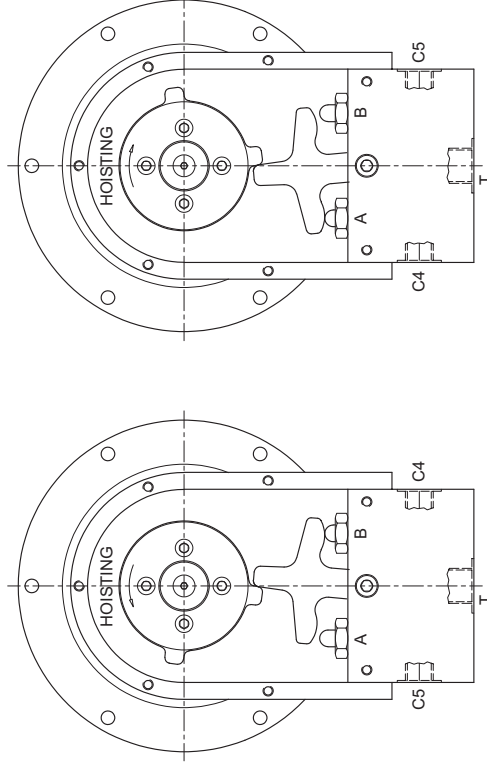

If the cams are rotating anticlockwise, the valve to make the drum stop while it is lifting is the valve on the right (B). If the cams are rotating clockwise, the valve to make the drum stop while it is lifting is the valve on the left (A).

Once the valve has been identified for stopping the drum while it is lifting, the other valve will stop it while it is lowering.

For the system to work correctly, the valve controlling the **LIFTING MUST BE CONNECTED** to attachment C4 of the overcentre valve, while the valve making the machine stop while **LOWERING** must be connected to attachment C5.

To calibrate the system, carry out the following steps:

LIFTING LIMIT

3) Position the crane hook 70-80 cm lower than the point where the winch should stop. Rotate the internal cam (5) and bring it into contact with the rocker arm (4), then tighten grub screw M4 (7).

Slowly turn the drum in the direction to lift the load, and check that the winch automatically stops before the hook or counterweight hit the return pulley.

LOWERING LIMIT

4) Unwind nearly all of the cable from the winch drum. Stop the drum with at least 6-7 coils of cable wound. Rotate the external cam (6) and bring it into contact with the rocker arm (4), then tighten grub screw M4 (8).

Slowly turn the drum in the direction to lower the load, and check that, when the winch automatically stops, there are still at least 4-5 coils of cable wound around the drum. Once complete, tighten the 4 screws (3).

5) Perform a few tests to ensure the winch stops in the correct position, both when lifting and lowering.

Once calibration is complete, grease the internal parts of the limit switch system thoroughly, especially the rocker arm and the end of the two locking valves.

Place the gasket in the rubber (10), close the cover (11), and reapply the 7 M5 screws (9). Max. tightening torque 6 Nm.

Typical hydraulic diagram for winch with hydraulic rotary limit switch

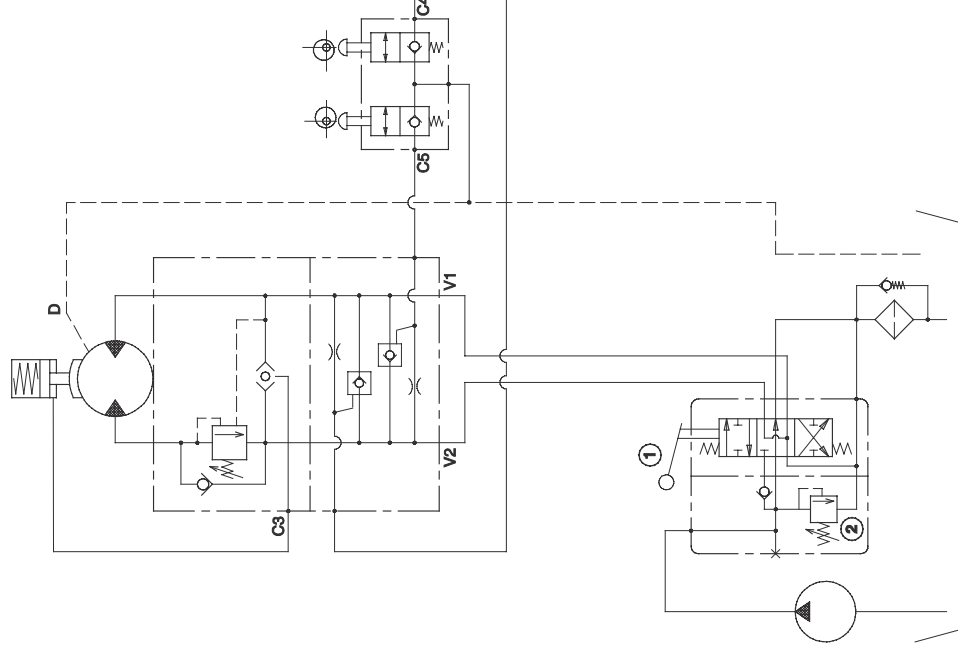

V1 = Lowering line	1 = Distributor with gate open
V2 = Lifting line	2 = Pressure relief valve
C3 = Connection to brake	3 = Rotary limit switch drainage
D = Connection to drainage	

10.9 LOAD LIMITER WITH STRAIN GAUGE

(only available for series NP, NPA, P, S and SE winches)

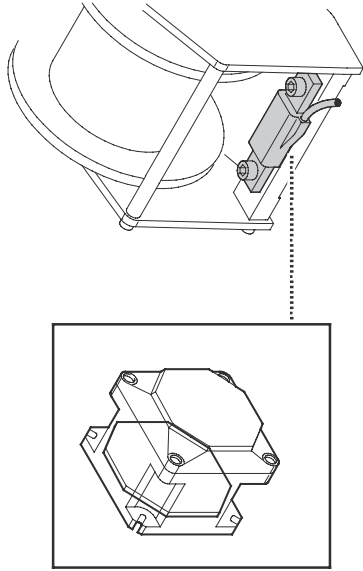

Consists of a strain gauge transducer and an electronics board. It stops the machine when the load being lifted exceeds the maximum weight permitted.

Electric/hydraulic diagram

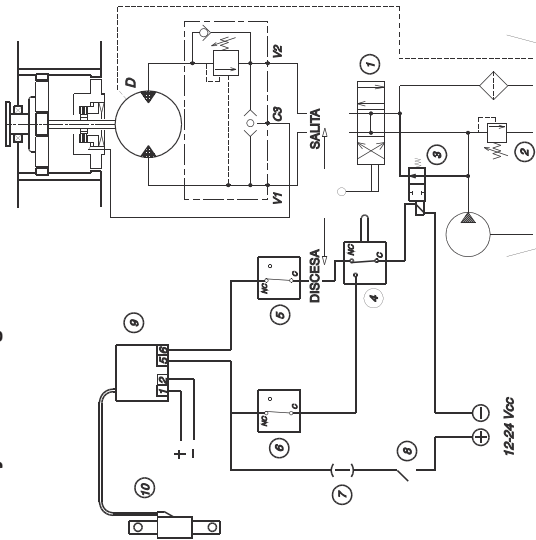

V1	= Lowering line	V2	= Lifting line
C3	= Connection to brake	D	= Connection to drainage
1	= Distributor with gate ope	2	= Pressure relief valve
3	= Discharge activation solenoid valve NO	4	= Reset microswitch
5	= Lifting limit microswitch	6	= Lowering limit microswitch
7	= Fuse	8	= Limit switch activation key
9	= Electronics board	10	= Strain gauge transducer

Overall dimensions

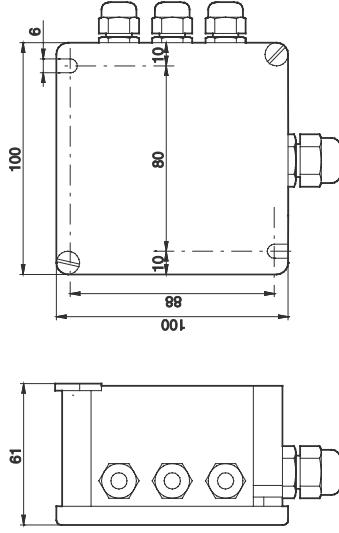
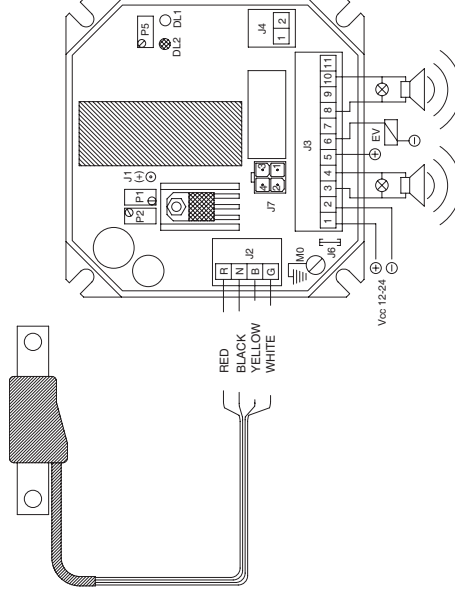

Diagram of connections on the electronics board



J3 connector: power supply, alarm output, alarm and prealarm signals

Terminal	Definition	Notes
1	Positive power supply	Connect directly to the battery positive terminal
2	Negative power supply	Connect directly to the battery negative terminal
3	Alarm signal	Positive signal
4	Service negative	Max. current 0.5 A
5	Relay output: contact C	Alarm output
6	Relay output: contact NO	I _{max} 8 A
7	Relay output: contact NC	
8	Service negative	Reset button
9	Reset input	
10	Pre-alarm signal	Positive signal. Connect the other end of the indicator to a service negative Max. current 0.5 A.
11	-	-

J4 connector: test input

Terminal	Definition	Notes
1	Service positive	Test button
2	Test input	Test button

J6 connector: connection to earth

Terminal	Definition	Notes
1	System earth connection	To be used when impossible to connect the box to earth

J7 connector: additional alarm output

Terminal	Definition	Notes
1	Relay output: contact NC	
2	-	
3	Relay output: contact NO	Additional I _{max} alarm output = 3 A
4	Relay output: contact C	

Checks after mounting

- Check that the battery voltage is correct (within the range of values allowed for the board, and without oscilloscope fluctuations in the signals)
- Check that the box closes properly and that the cable glands are sufficiently tightened
- Check that the device can be switched off using the master switch
- Check that the box's metal board is electrically connected to the vehicle mass.

Calibrating the electronics board

Information: a final calibration check of the machine is recommended after a number of lifting tests have been performed to take account any settlement.

Introduction

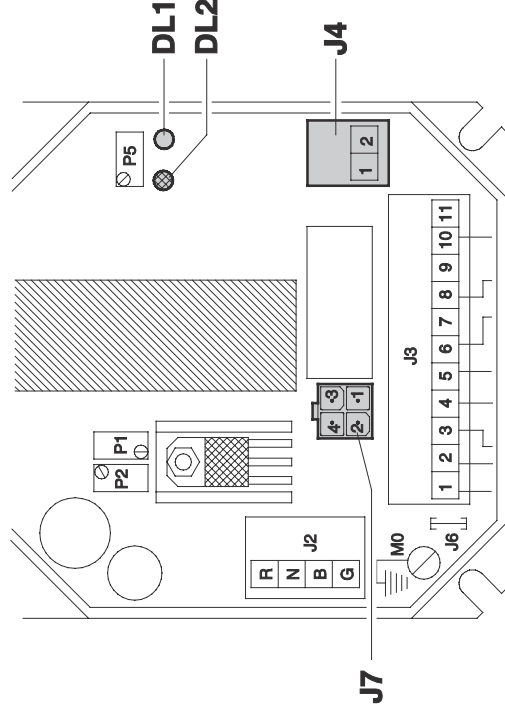

Calibration must be only be performed once the winch has been installed. The board has an internal relay (5-6 contacts, max. 8 A), or it can control an external relay (J7 connector max. 3 A).

The board can check it is functioning correctly (not calibration) with an external button connected to the J4 connector, contacts 1-2. Make the connections and press the external button. The board MUST be locked, simultaneously switching on the alarm and prealarm DL2 - DL1.

Calibrating the load limiter

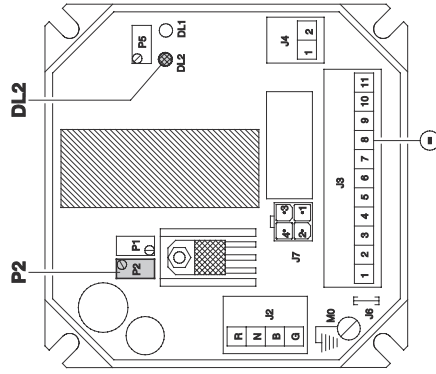

Make the electrical connections as shown in the diagram, and start the current. If the red LED DL2 switches on, turn the P2 trimmer clockwise until it switches off. With the winch stopped, use the machine arm to lift a load greater than 10 % of the winch's maximum pull, with the cable wound around the last groove. If the calibration is performed on a groove other than the last one, contact our technical office. Now, turn the P2 trimmer anticlockwise until the red LED lights up.

Calibrating the prealarm

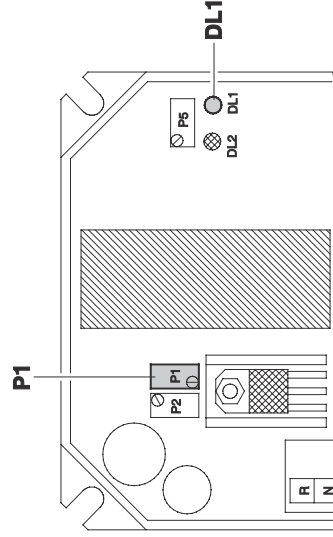

Lift a load less than 10 % of the winch's maximum load capacity on the last groove.

- A) If the yellow LED DL1 is lit, turn the P1 trimmer clockwise until it goes off.
- B) If the yellow LED DL1 is off, turn the P1 trimmer anticlockwise until it lights up.

Calibrating the alarm output delay time

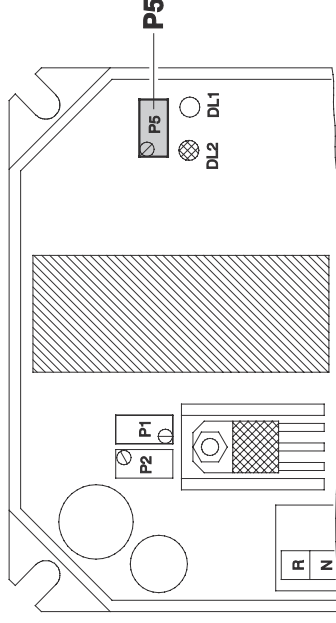

Adjust the alarm output delay time from 0 to 5 seconds using the P5 trimmer. Each clockwise turn of the trimmer increases the relay's closing time by 0.5 seconds

10.10 LOAD CELL STRAIN GAUGE LIMITER

(only available for series P9, S19, S20, SE20 and SE30 winches)

This device can detect and restrict the load on the hook, using two load cells attached to the winch's anchoring surface.

(The anchoring surface is supplied with the winch.)

The winch is not fastened rigidly to the surface, and its load can make it imperceptibly move around, acting on the load cells.

An electronics board then turns the signal coming from the load cells into a signal that can be used as an alarm to stop the machine and to see the load being lifted.

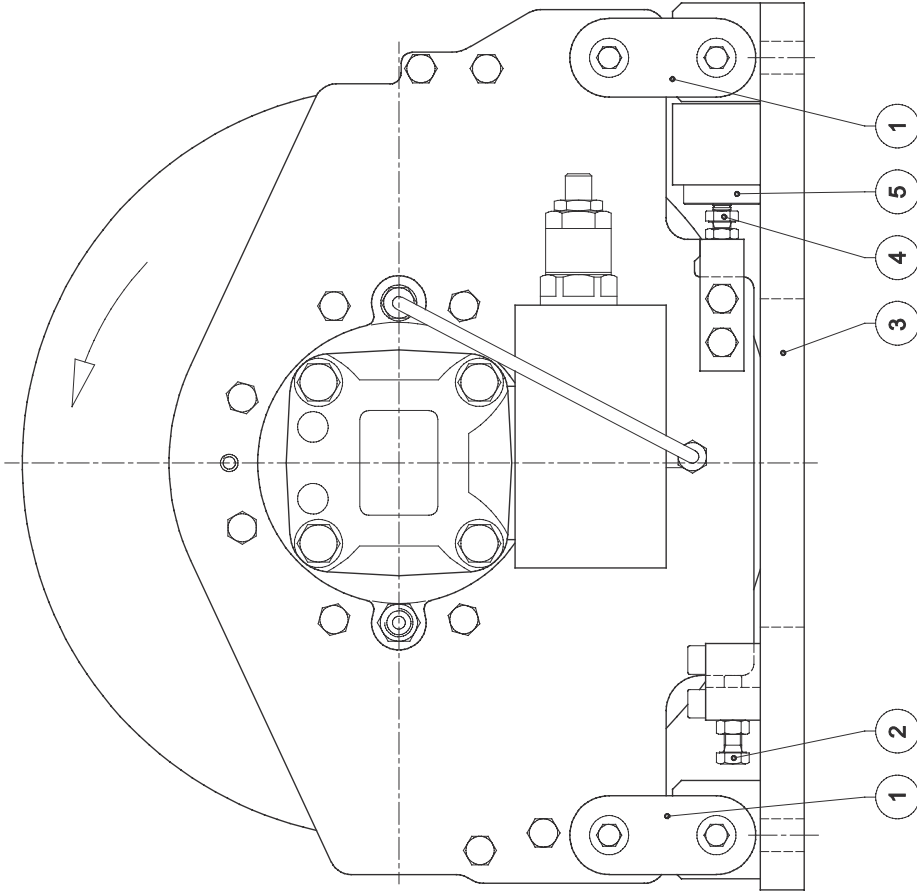

- 1 = Connecting rod between winch and surface
- 2 = Slack adjustment screws and preload for load cells
- 3 = Anchoring surface
- 4 = Cell touch probe screws
- 5 = Load cells

Adjusting the load cell strain gauge limiter

- 1) Loosen the screw (2)
- 2) Insert the screw (4) into the cell (5).
- 3) Tighten the screw (2) until it touches the winch support (the cells can be preloaded by tightening it further).

Electrohydraulic diagram with load cell limiter

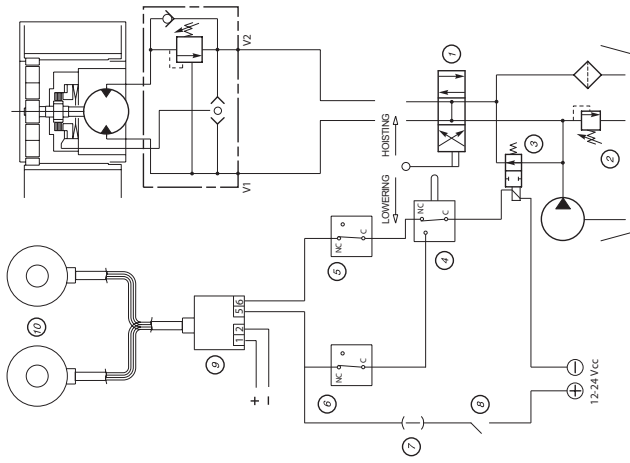

V1	= Lowering line	V2	= Lifting line
C3	= Connection to brake	D	= Connection to drainage
1	= Distributor with gate open	2	= Pressure relief valve
3	= Discharge activation solenoid valve NO	4	= Reset microswitch
5	= Lifting limit microswitch	6	= Lowering limit microswitch
7	= Fuse	8	= Limit switch system activation key
9	= Electronics board	10	= Load cells

10.11 UNLOCKING THE DRUM WITH MANUAL BALL VALVES

(only available on request)

This emergency device allows the drum to be unlocked, and the load to be lowered in a controlled manner. It is usually operated using a hand pump. In addition to the parts listed below, this accessory requires a special overcentre valve which must be requested at the time the winch is ordered.

Typical hydraulic diagram

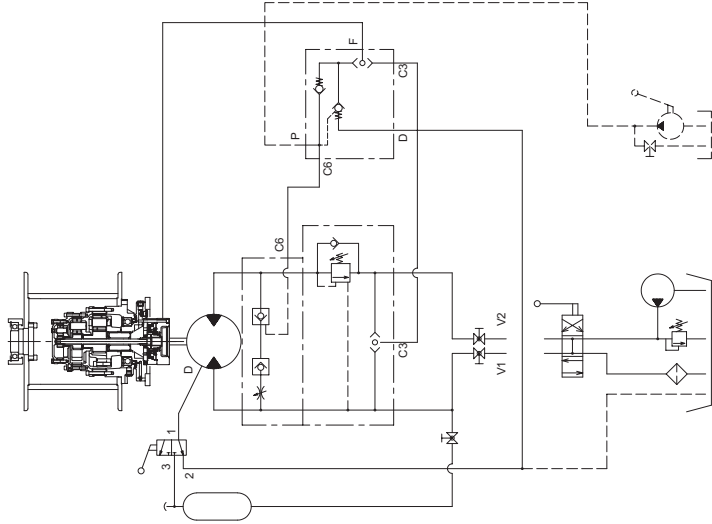

V1	= Lowering line	V2	= Lifting line
C3	= Connection to brake	D	= Connection to drainage
C6	= Connection to drum unlock controller	P	= Connection to hand pump
F	= Connection to brake		

Parts required

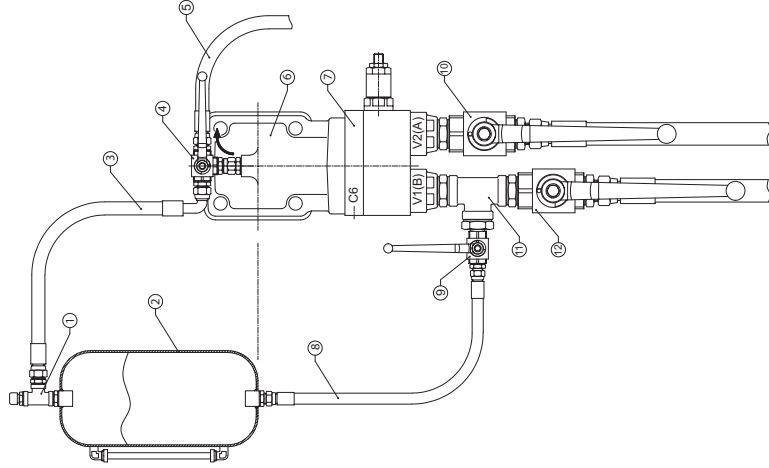

1	= T-piece	7	= Overcentre valve
2	= Tank	8	= Flexible tube
3	= Flexible tube	9	= 2-way ball valve
4	= 3-way ball valve	10	= 2-way ball valve
5	= Flexible tube	11	= T-piece
6	= Hydraulic motor	12	= 2-way ball valve

Assemble the components as shown in the diagram on page 3.
Dinamic Oil recommends the following sizes of connectors and ball valves:

- Additional tank (2) at least 5 litres in size, filled with 4 litres of the same oil used in the winch,

- attached with 3/8" G BSP
- 3-way ball valve (4), attached with at least 1/2" G BSP.
- Ball valve (9), attached with 3/8" G BSP.
- T-piece (11) for nominal pressures of 150 bar, see winch data sheet for attachment sizes.
- Ball valve (10 and 12) for other pressures (>300 bar), see winch data sheet for attachment sizes.

The additional tank (2) must be placed higher than the motor (6). This placement allows the flexible tube (8) and the motor to remain full of oil during the emergency lowering phase.

Operation in normal usage conditions

As shown in the diagram below, during normal winch operation, the ball valves (10 and 12) need to be kept open, the ball valve (9) closed, and the 3-way ball valve (4) must allow flow between the motor drainage gate and the flexible tube (5) (machine connection to the tank).

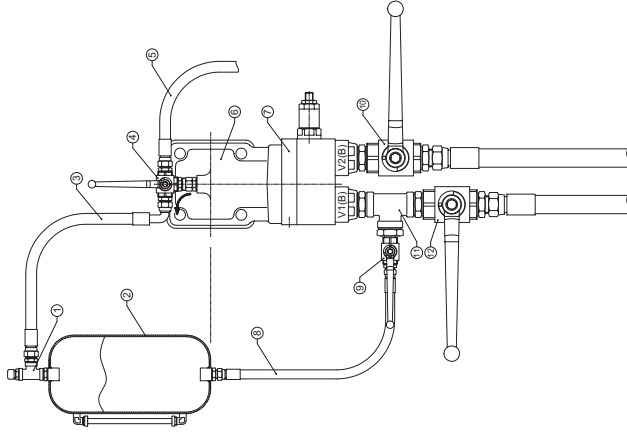

Operation in emergency conditions, unlocking the drum

As shown in the diagram below, in emergency conditions the following procedure must be followed:

- Check the oil level using the visual level on the side of the tank 2
- Close the ball valves (10 and 12)
- Open the ball valve (9)
- Activate the 3-way ball valve (4) to allow flow between the motor drainage gate and the flexible tube (3) connected to the additional tank.

The drum unlock controller can only be activated once this sequence of operations has been completed.

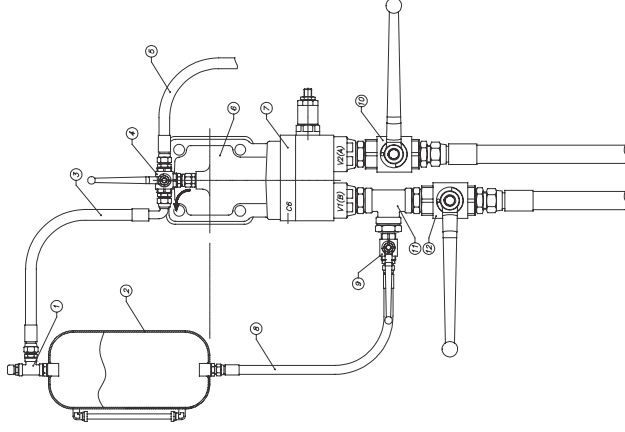

Caution

Once the emergency operation has been performed, it is important that the system is restored as shown in the "Operation in normal usage conditions" section to prevent the winch from malfunctioning or being damaged. The diagrams in those instructions are to be used as a guide only. For other configurations, refer to the instructions shown here and the entries in the relevant data sheet.



10.12 UNLOCKING THE DRUM “AUTOMATICALLY”

(only available on request)

This emergency device allows the drum to be unlocked, and the load to be lowered in a controlled manner. It is usually operated using a hand pump. In addition to the parts listed below, this accessory requires a special overcentre valve which must be requested at the time the winch is ordered.

Typical hydraulic diagram

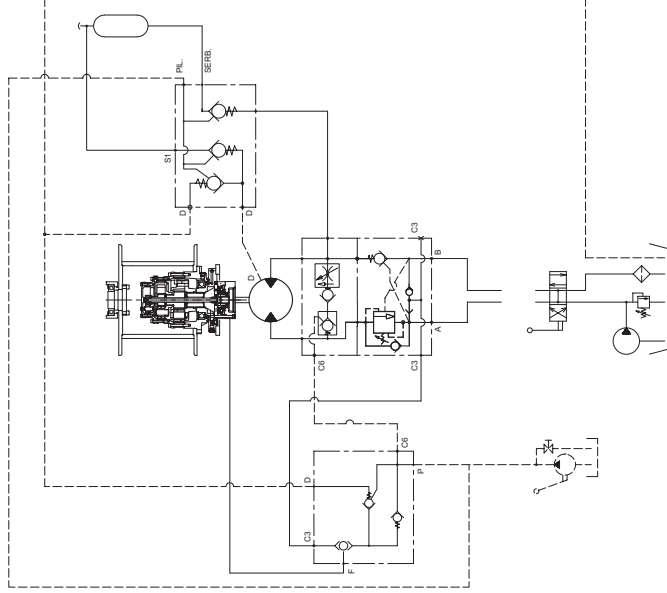

A	= Lowering line	B	= Lifting line
C3	= Connection to brake	D	= Connection to drainage
C6	= Connection to drum unlock controller	P	= Connection to hand pump
F	= Connection to brake	S1	= Connection to tank
Serb	= Connection to tank		

Unlocking the drum

To unlock the drum, a hand pump just needs to be connected to gate P shown on the data sheet. By applying pressure, it is possible to lower the cable in a controlled manner. The maximum pressure in gate P is 100 bar.

10.13 AUTOMATIC CABLE GUIDE

(only available on request)

This device is used to correctly guide the cable onto the drum. The system is completely automatic, and allows the winch to be used even when the cable is significantly tilted (see paragraph 4.9)

Adjusting the automatic cable guide

Operate the winch by turning the drum in the winding direction, bringing the box to face the side where the cable will be installed.

While continuing to turn the drum, the box will reach its limit position. As soon as it stops, stop the winch. Unscrew the shaft clamping screws. This will free the threaded bar from the rotation of the drum, meaning the cable guide box will stay still even when the drum is turning.

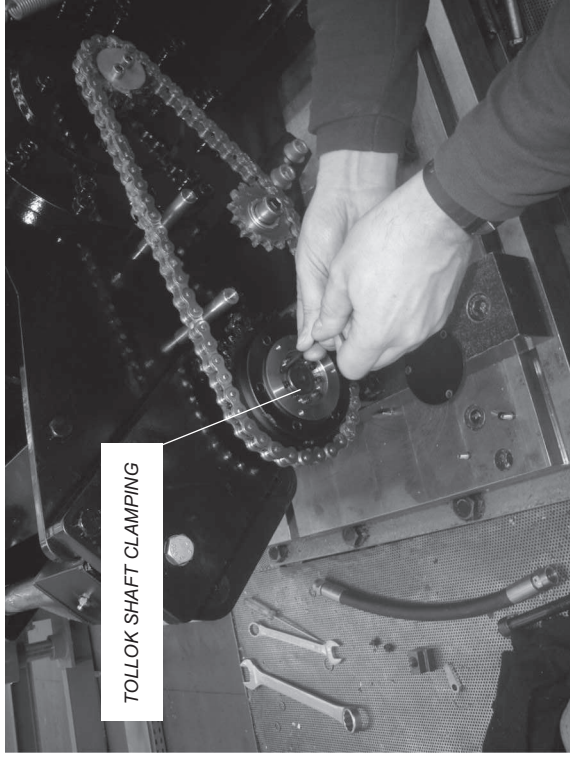

Rotate the drum until the slot is at the top.

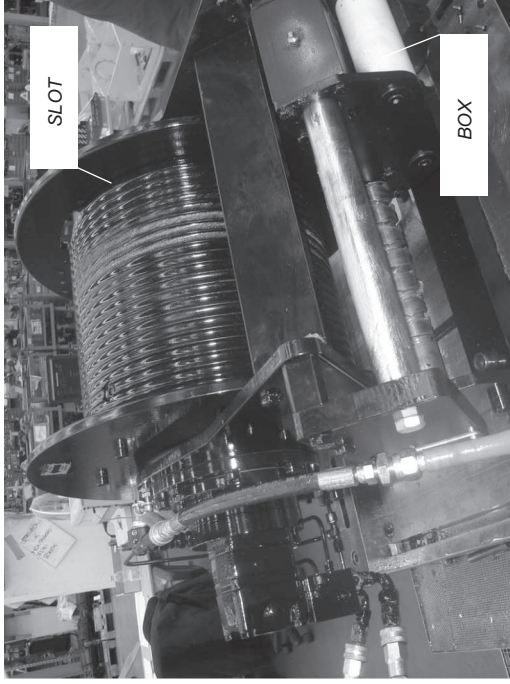

Feed the cable onto the cable guide rollers, threading it through the slot and locking it with the clamps or thimble, taking care not to let the cable protrude out of the sides.

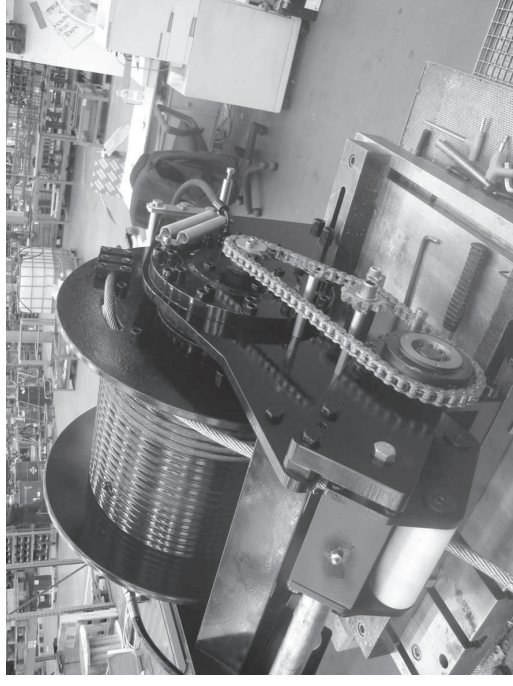
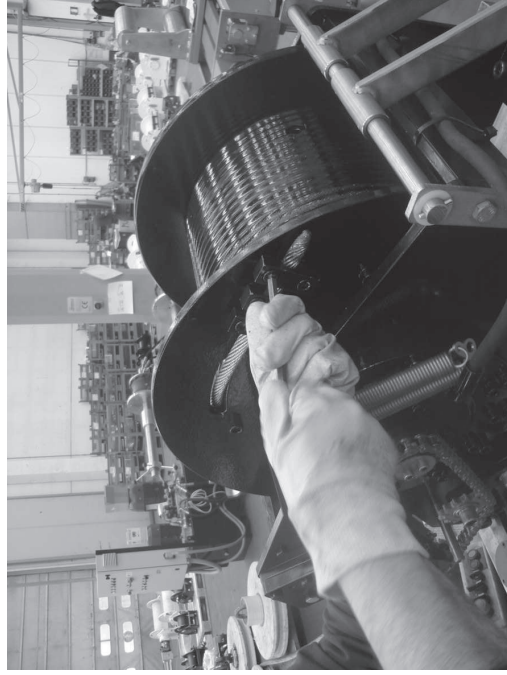

Tighten the shaft clamping screws and activate the winch. If everything has been done correctly, the drum will make a complete turn, and the box will then start moving, remaining one coil behind the drum.

